

HIGH-FIDELITY FULL AUTOMATIC

STEREO TURNTABLE

**PL-117D**

KUT, KCT, HGT, QT, Q

<ART-166-0>

# *Service Manual*



 **PIONEER®**

# CONTENTS

1.	SPECIFICATIONS (KCT, KUT model) .....	3
2.	PANEL FACILITIES .....	4
3.	OPERATION .....	6
4.	PARTS LOCATIONS	
4.1	Top View .....	7
4.2	Bottom View .....	9
5.	EXPLODED VIEW	
5.1	Main Panel .....	11
5.2	Sub Panel .....	13
5.3	Tone Arm Assembly (PPD-535) .....	15
5.4	Function Button Assembly (PXA-216) .....	16
5.5	Elevation Lever Assembly (PXA-142) .....	16
5.6	Speed Selector Button Assembly (PXA-124) .....	17
5.7	Disc Size Lever Assembly (PXA-143) .....	17
5.8	Cabinet .....	18
5.9	Packing .....	19
6.	NOMENCLATURE OF SCREWS, WASHERS AND NUTS .....	20
7.	WIRING	
7.1	K model (KCT, KUT) .....	21
7.2	H model (HGT) .....	21
7.3	Q model (Q, QT) .....	21
8.	ADDITIONAL INFORMATION	
8.1	HGT model .....	22
8.2	Q, QT model .....	23
8.3	Q model .....	24
9.	SPECIFICATIONS (HGT model) .....	25
10.	SPECIFICATIONS (QT, Q model) .....	26
11.	OPERATING DESCRIPTION .....	27
11.1	Automatic-operation Detection .....	29
11.2	Microswitch ON-OFF .....	30
11.3	Auto-cut and Auto-return Detection .....	31
11.4	Tone Arm Operation .....	32
11.5	Muting Switch ON-OFF .....	35
11.6	Record Size Selector .....	35
11.7	Arm Elevation .....	35
12.	ADJUSTMENT	
12.1	Start Adjustment .....	36
12.2	Repeat Adjustment .....	36
12.3	Stop Adjustment .....	37
12.4	SS Operating Section Adjustment .....	37
12.5	EV Operating Section Adjustment .....	38
12.6	Return Position Adjustment .....	38



# 1. SPECIFICATIONS (KCT, KUT model) HGT model on page 25. QT, Q model on page 26.

## Motor and Turntable

Motor .....	4-pole synchronous
Turntable drive .....	Belt-driven
Speed .....	Two speeds: 33-1/3rpm, 45rpm
Wow and flutter .....	0.07% (WRMS) or less
S/N .....	50dB (JIS) or more (with Pioneer cartridge model PC-135)
Turntable platter .....	30cm diam. aluminum alloy
Moment of inertia .....	135kg-cm <sup>2</sup> (including rubber mat)

## Tonearm

Tonearm type .....	Static-balance, S-shaped, pipe arm
Effective arm length .....	221mm
Tracking error .....	+3° ~ -1°
Overhang .....	15.5mm
Usable cartridge weight .....	4g (min.) ~ 10g (max.) (For cartridge weighs over 8.5g, attach the sub weight)

## Sub Functions

Fully automatic tonearm system
Anti-skating force control device
Plug-in type headshell
Oil-damped arm elevator device
Hinges (Free adjustable)
Lateral balancer

## Miscellaneous

Power requirements .....	AC 120V, 60Hz
Power consumption .....	10W
Dimensions .....	440(W)x362(D)x159(H) mm 17-5/16(W)x14-1/4(D)x6-1/4(H) in.
Weight .....	7kg, 15 lb 6 oz

## Accessories

Headshell .....	1
Accessory oil .....	1
Overhang gauge .....	1
45rpm adaptor .....	1
Screwdriver .....	1
Sub weight .....	1
Cartridge mounting screws .....	6
Cartridge mounting nuts .....	2
Cartridge mounting washers .....	2
Operating instructions .....	1

### NOTE:

Specifications and the design subject to possible modification without notice due to improvements.

## 2. PANEL FACILITIES

### HEADSHELL STAND

A spare headshell can be stored in this stand. Align the headshell pins with the stand grooves and insert. Observe that the headshell length is not greater than the height of the dust cover. This stand can also be used for storing the 45 rpm adaptor.



### SPEED SELECTOR BUTTONS

Press the button corresponding to the correct speed of the record to be played (press "33" button for 33-1/3 rpm). Be sure to change speeds only while platter is rotating.

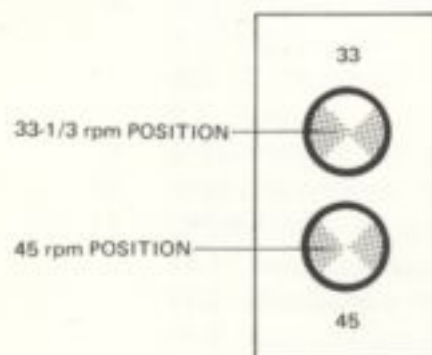

### 45 RPM ADAPTOR

Place on center shaft when playing 45 rpm EP records.



### ARM REST

Supports the tonearm when not playing a record. At the end of a playing session, engage the clamp as illustrated below.

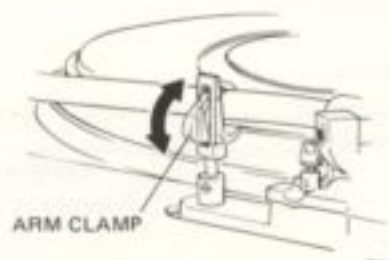

### ARM ELEVATION LEVER

Tonearm is raised and lowered by operating this lever.  
**UP** ..... Set to this position to raise tonearm during play.  
**DOWN** .... Set to this position for automatic play or to lower the tonearm during manual play.

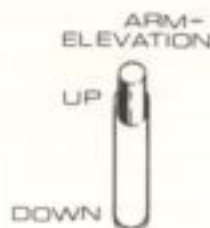

## A PARTS LOCATIONS

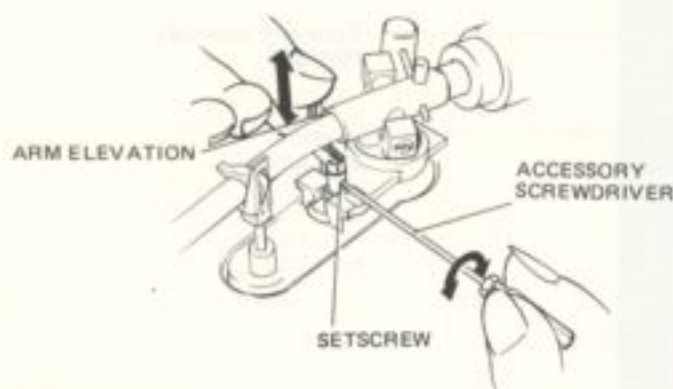
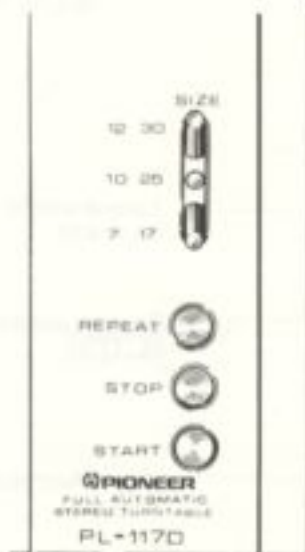

### SIZE LEVER

Set according to record diameter during automatic play.

**12" 30:** Set to this position to play standard 12-inch (30cm) LP record.

**10" 25:** Set to this position to play standard 10-inch (25cm) record.

**7" 17:** Set to this position to play standard 7-inch (17cm) record.

#### NOTE:

Be sure to set the **SIZE** lever before pressing the **START** button. Incorrect operation can occur if set during lead-in motion.

### FUNCTION SELECTOR BUTTONS

**REPEAT ..** Depress this button to repeatedly play the same side of a record. To release the repeat mode, press the **STOP** button.

**STOP .....** While a record is playing, press to interrupt play and return the tonearm to the arm rest. Platter drive and power will be shut off. Also, press this button to release the **REPEAT** button.

**START ...** Press for normal record playing. Since the internal mechanism becomes locked, it is not necessary for the button to remain depressed.

#### NOTE:

Be sure to set the **ARM ELEVATION** lever to the **DOWN** position for automatic play. If set to the **UP** position, the automatic play operation will not be performed.

### ARM ELEVATION

Arm elevation may require adjustment according to cartridge height. If necessary use the accessory screwdriver to loosen the setscrew and adjust (see figure).

### OPERATING PRECAUTIONS

- Keep stylus and records clean. Use a stylus brush to clean the stylus and a good quality record cleaner to clean the records each time before and after playing.
- Avoid exerting unnecessary force on the tonearm. When changing headshells, set the tonearm in the arm rest and engage the clamp.
- Spring flotation is applied to the turntable when clamp screws are removed. Although the turntable may appear unsteady, this does not indicate a problem.
- Take care not to impart vibration to the turntable while a record is playing. Record and stylus can be damaged.
- Never touch the speed select buttons if the turntable is stationary. The speed can be changed only while the turntable is rotating.
- Never obstruct the turntable while it is rotating. This may cause damage.
- Avoid placing 2 or more records on the turntable simultaneously. The mechanism is balanced for proper operation with only one record in place.



### 3. OPERATION

#### AUTOMATIC PLAY

1. Unfasten tonearm clamp.
2. Set ARM ELEVATION lever to DOWN.
3. Remove the stylus cover and place record on the platter.
4. Set the SIZE lever according to record diameter: 12" 30, 10" 25, or 7" 17.

The second number in each group is the size in centimeters.

5. Press START button. While platter is rotating, press speed selector button according to record speed. Approximately 5 seconds later, the tonearm will be brought over the record starting point (as selected by the SIZE lever) and the stylus will be slowly lowered onto the record to begin play.
6. Adjust volume and tone controls on the stereo amplifier being used for desired volume and tone.
7. After playing the record, the auto return mechanism functions to return the tonearm to the arm rest. About 5 seconds later, platter drive and power are shut off.

#### NOTE:

If the REPEAT button is in its depressed position, the record will be played repeatedly. When this function is not desired, release the REPEAT button by pressing the STOP button before playing.

#### MANUAL PLAY

1. Unfasten the arm clamp.
2. Set ARM ELEVATION lever to UP.
3. Remove the stylus cover and place record on the platter.
4. Grasp headshell finger grip and position the tonearm over the desired starting point of the record. After platter rotation starts, press the speed selector button according to record speed.
5. Set ARM ELEVATION lever to DOWN.
6. Adjust volume and tone controls on the stereo amplifier being used for desired volume and tone.
7. At completion of the record side, the auto return mechanism functions to return the tonearm to the arm rest. About 5 seconds later, platter drive and power are shut off.

#### NOTE:

Manual play can also be performed with the ARM ELEVATION lever in the DOWN position. At this time however, use particular care not to damage the stylus or record.

#### REPEAT PLAY

Perform steps 1 through 4 of the Automatic Play section.

5. Press the REPEAT button, then the START button.
6. Adjust volume and tone controls on the stereo amplifier being used for desired volume and tone.
7. At the completion of the record side, the auto return mechanism functions to return the tonearm to the arm rest. Thereafter, the tonearm is again brought over to the record and play begins. This cycle repeats indefinitely until released by pressing the STOP button.

#### RELEASING THE REPEAT FUNCTION

- During lead-in (as tonearm is moving toward platter): by pressing the STOP button, the record will be played once, then the repeat function will be released.
- During return (as tonearm is moving toward arm rest): by pressing the STOP button, the tonearm will continue toward the arm rest, then return to play the record once more. At the completion of play, the tonearm will again return to the arm rest, whereupon platter drive and power will be shut off.
- While record is being played: by pressing the STOP button, the tonearm is raised from the record and returned to the arm rest. Platter drive and power are then shut off.

#### STOPPING IN MIDST OF RECORD

- Press STOP button.  
The tonearm will be raised from the record and returned to the arm rest. Approximately 5 seconds later, platter drive and power will be cut off.
- Manually return tonearm to arm rest.  
Platter drive and power will be shut off.

#### NOTE:

The REPEAT PLAY function can not be started by pressing only the REPEAT button.

To start the repeat play it is necessary to press the repeat and start buttons.

# 4. PARTS LOCATIONS

## 4.1 TOP VIEW

AC power cord  
KDG-011 (KCT, KUT model)  
PDG-004 (Q, QT model)

Headshell stand  
PNW-073

Capstan  
PLA-040 (60Hz)

Angle

Center shaft  
PXA-134

Cam  
PNW-124

Speed selector panel  
PAN-017

Main panel  
PNW-078



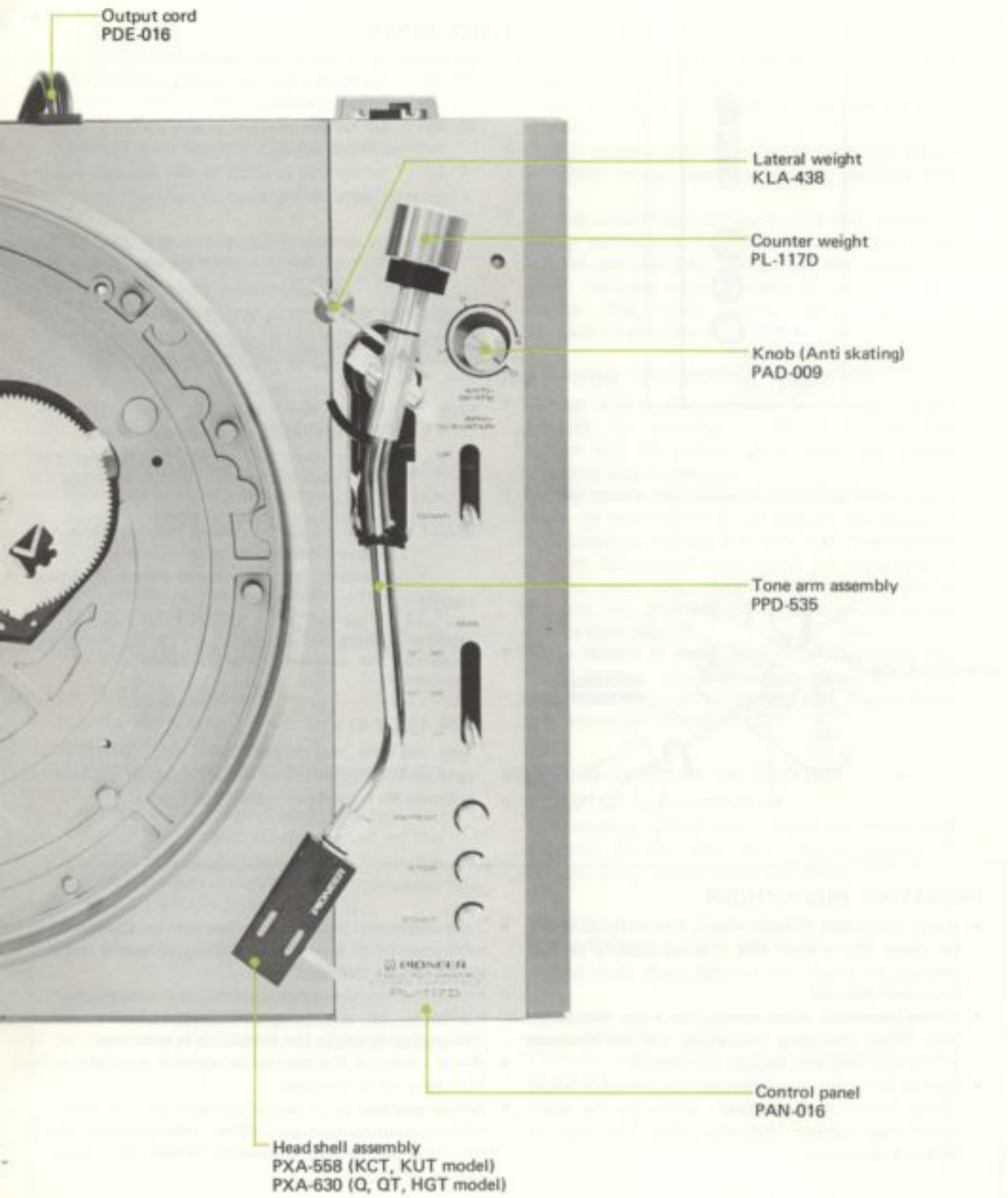



## 4.2 BOTTOM VIEW

Microswitch  
KSF-023

Rubber grommet (B)  
PEB-011

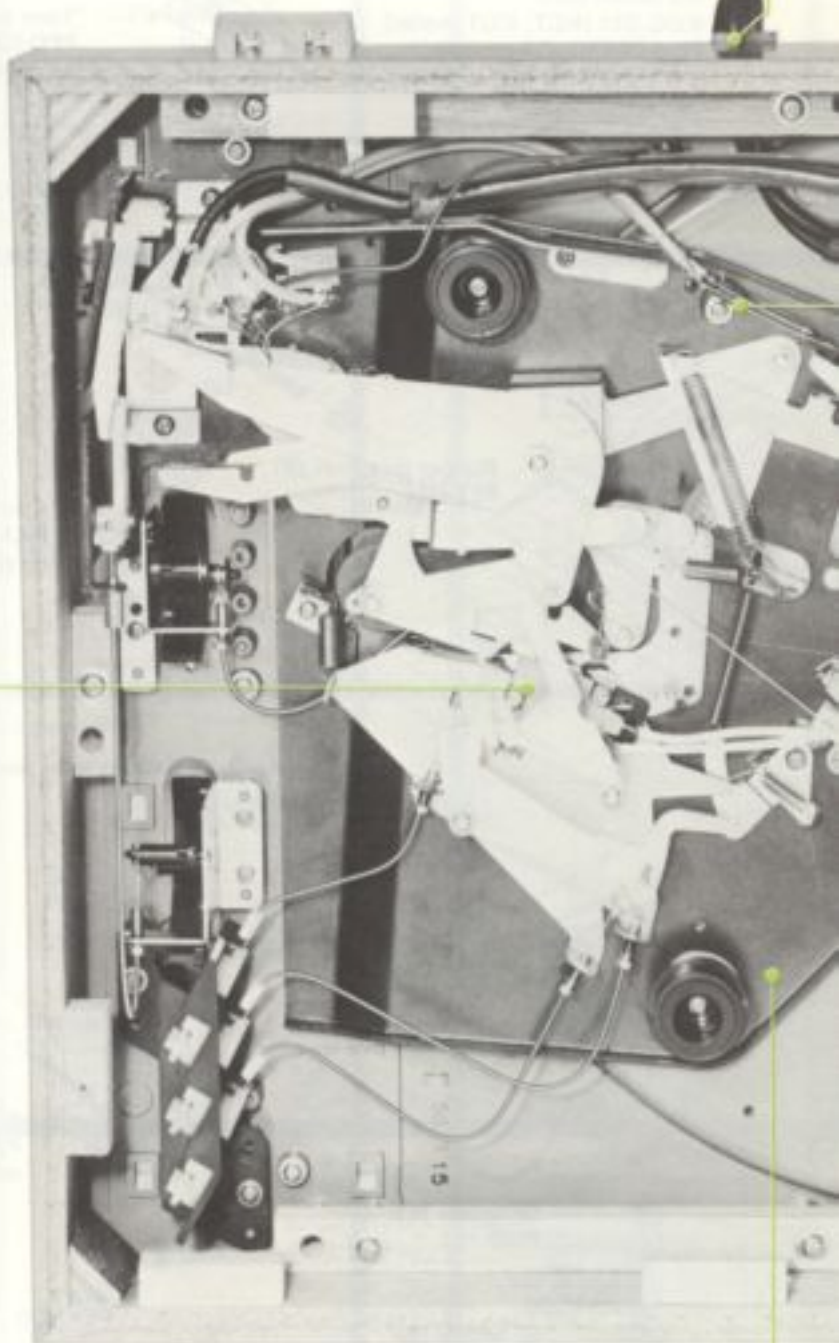

Sub-panel

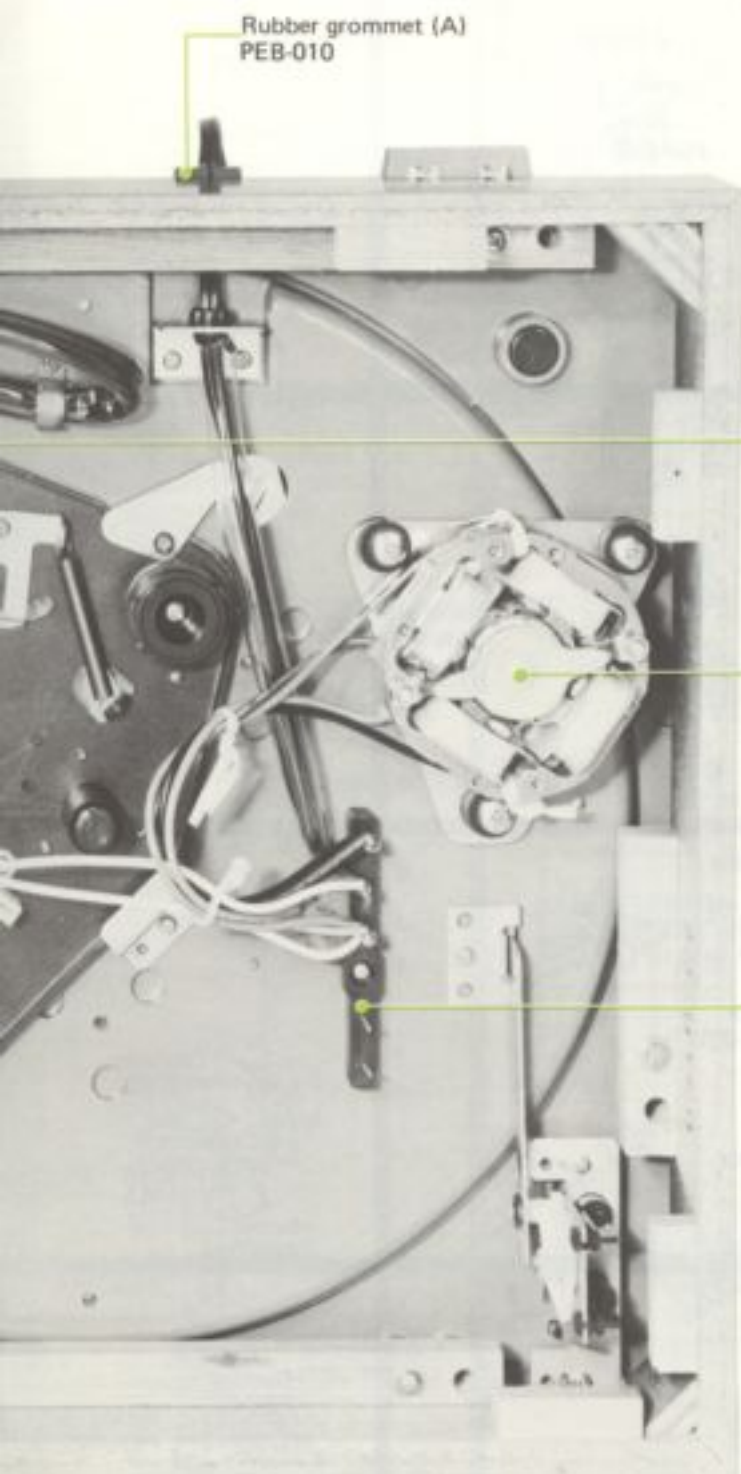

Rubber grommet (A)  
PEB-010

Leaf switch  
PSN-001

Motor  
PXM-032

Terminal  
PKC-004

# 5. EXPLODED VIEW

## 5.1 MAIN PANEL

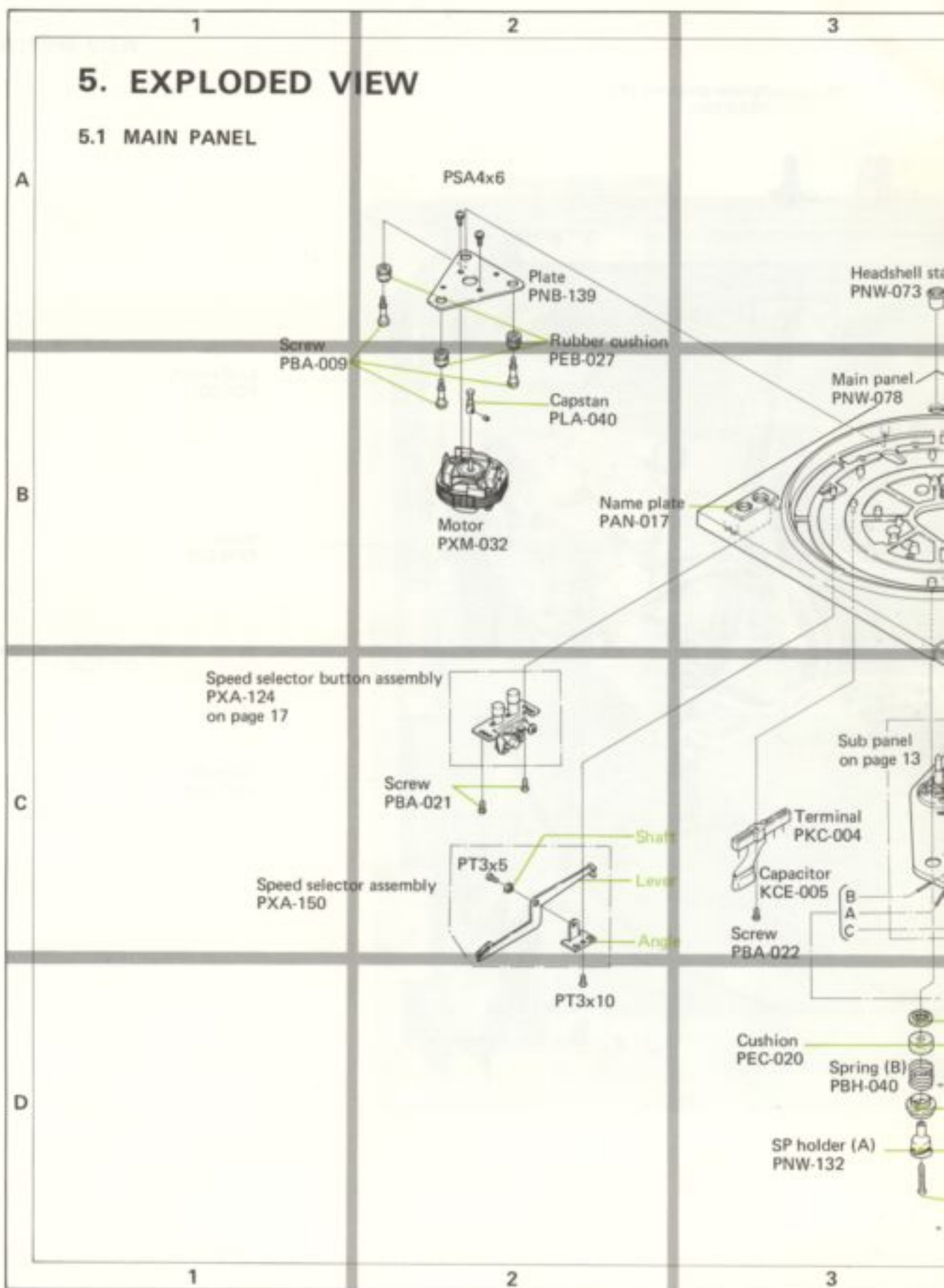



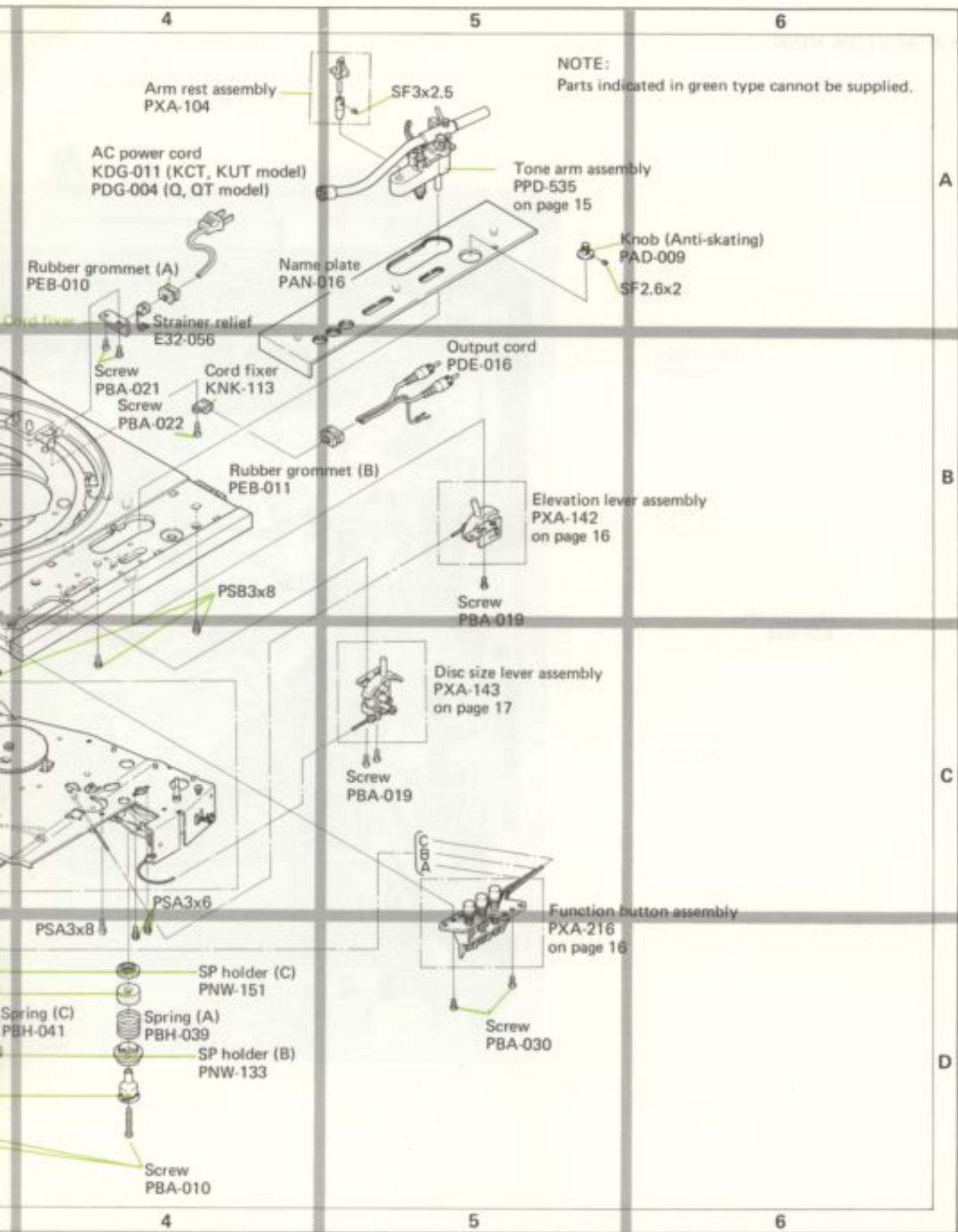

5.2 SUB PANEL

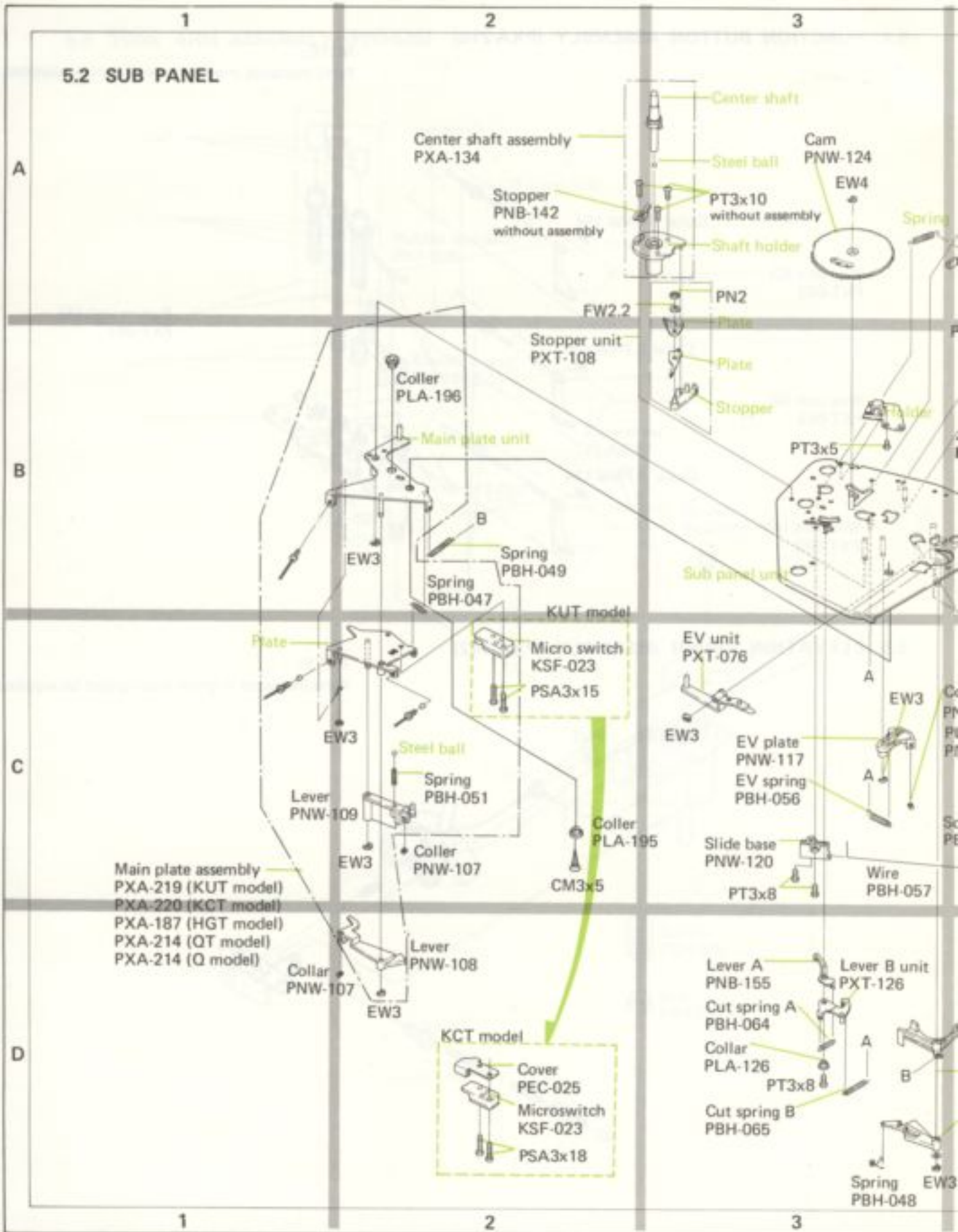

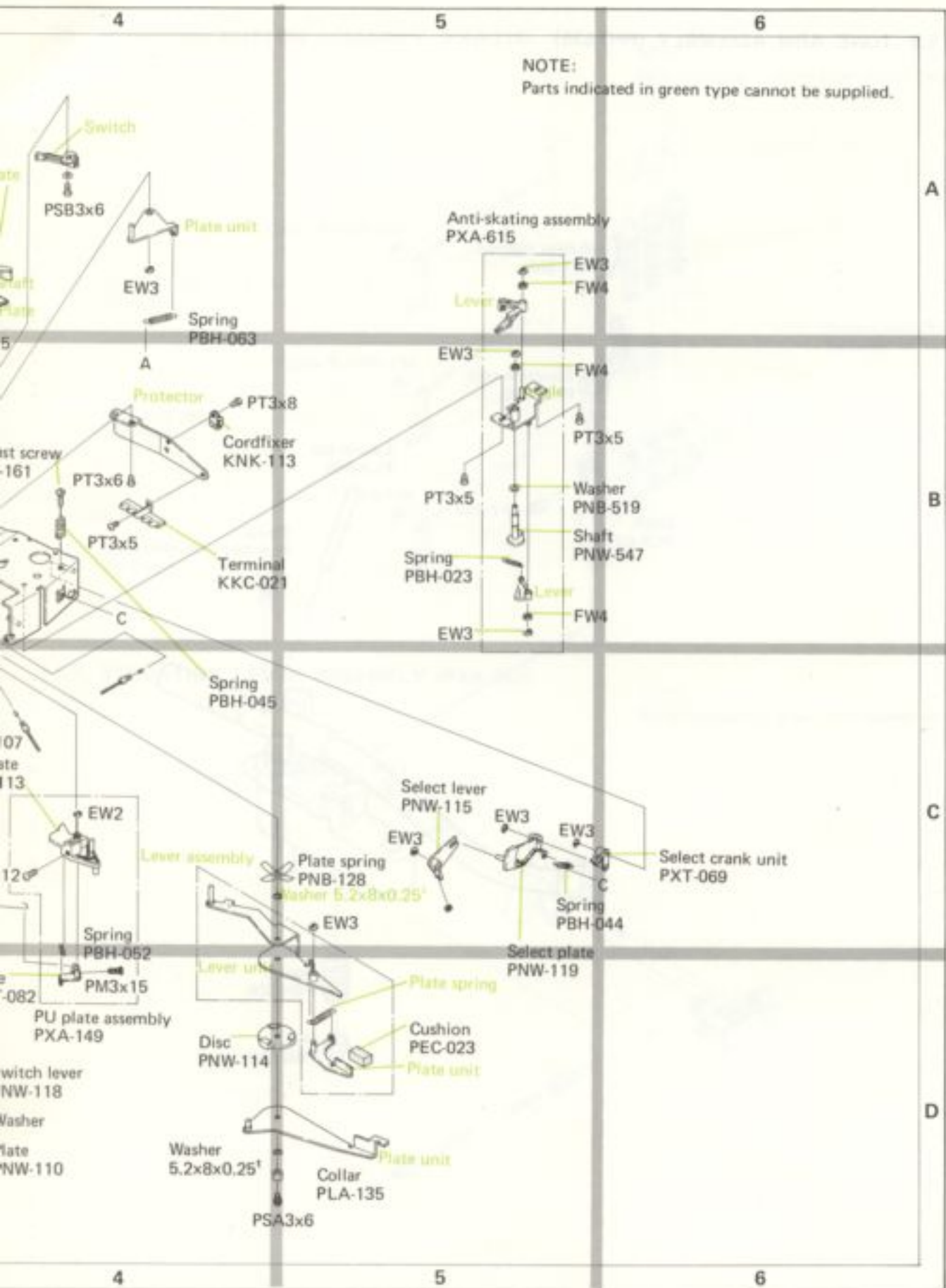



### 5.3 TONE ARM ASSEMBLY (PPD-535)

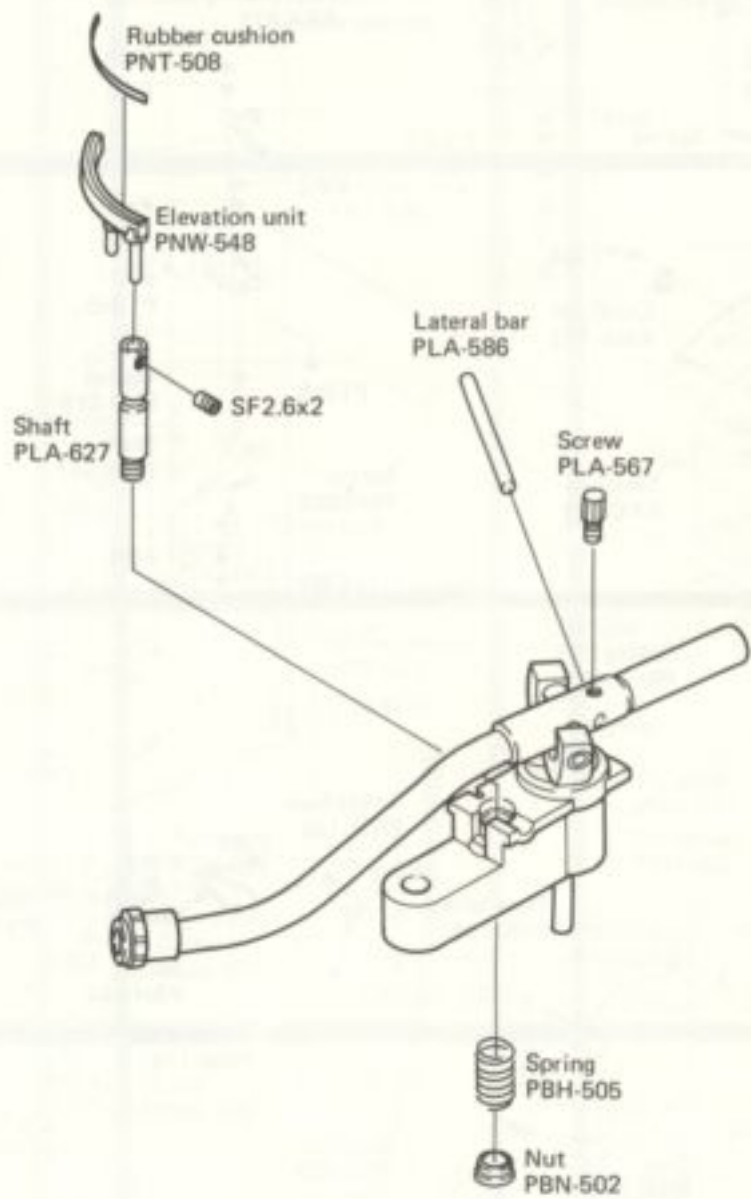

## 5.4 FUNCTION BUTTON ASSEMBLY (PXA-216)

NOTE:

Parts indicated in green type cannot be supplied.

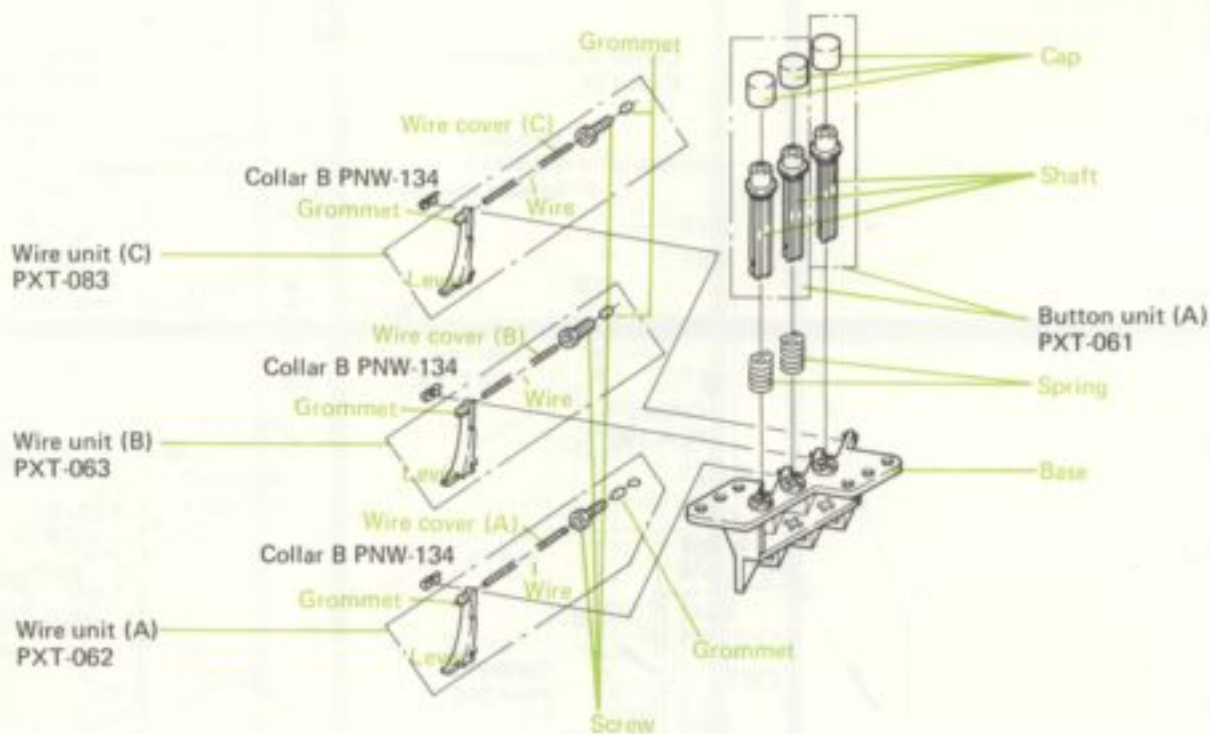

## 5.5 ELEVATION LEVER ASSEMBLY (PXA-142)

NOTE:

Parts indicated in green type cannot be supplied.

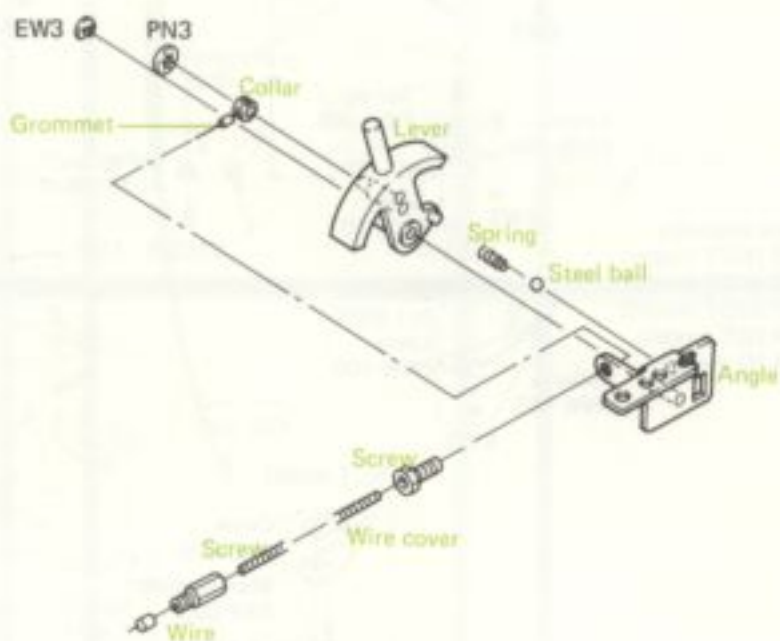

5.6 SPEED SELECTOR BUTTON ASSEMBLY (PXA-124)

NOTE:  
Parts indicated in green type cannot be supplied.

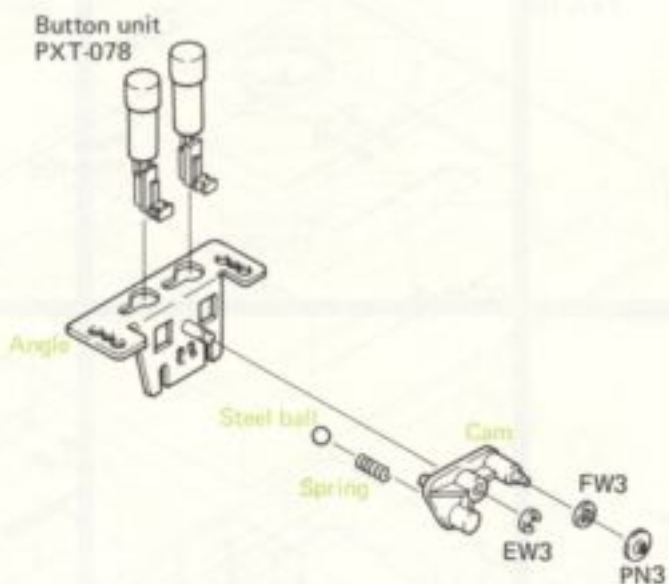

5.7 DISC SIZE LEVER ASSEMBLY (PXA-143)

NOTE:  
Parts indicated in green type cannot be supplied.

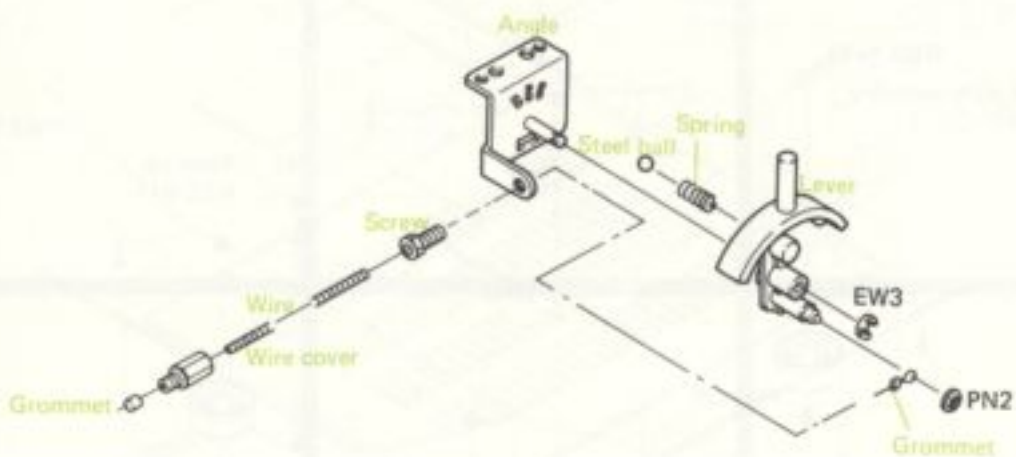



## 5.8 CABINET

NOTE:

Parts indicated in green type cannot be supplied.

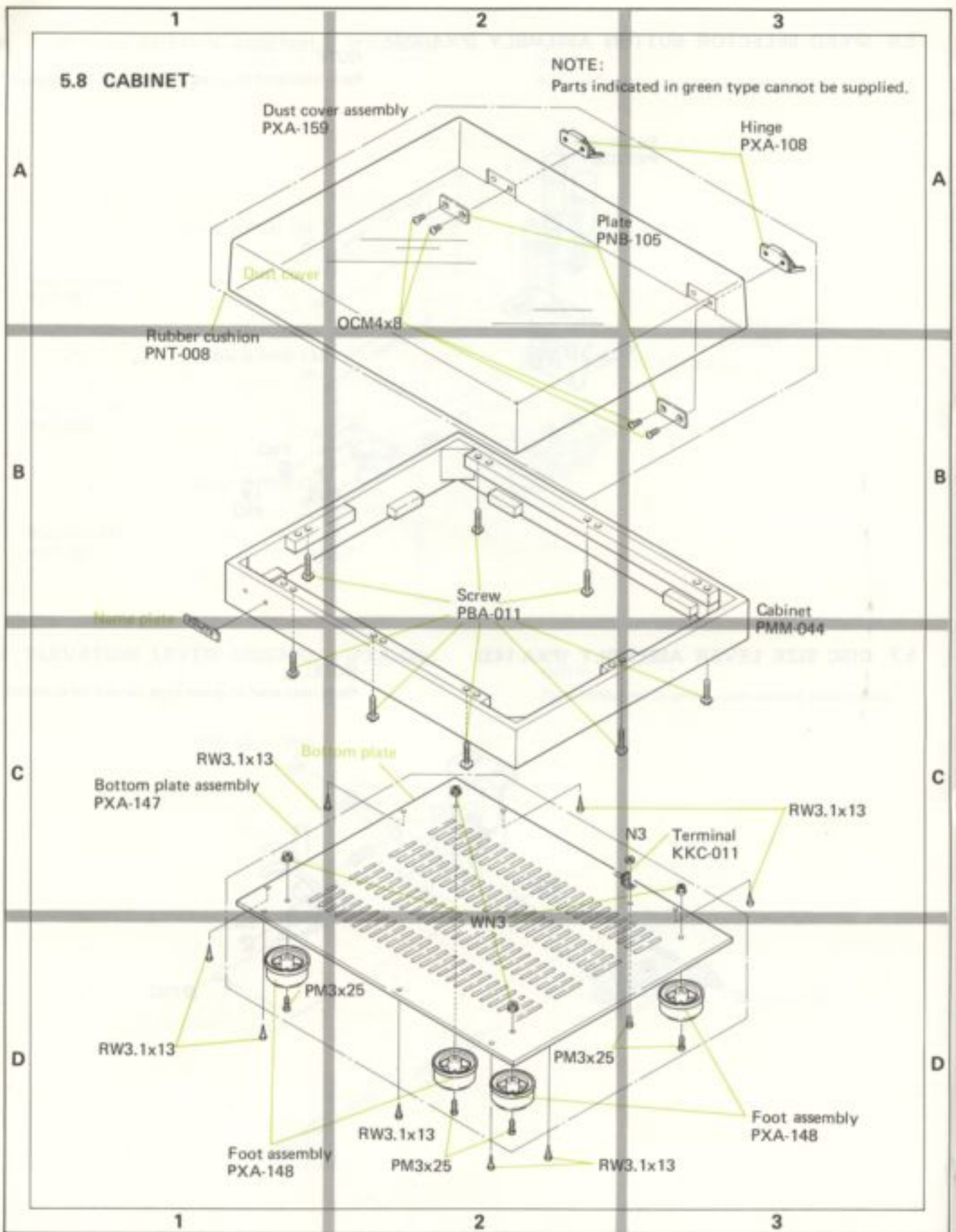

5.9 PACKING





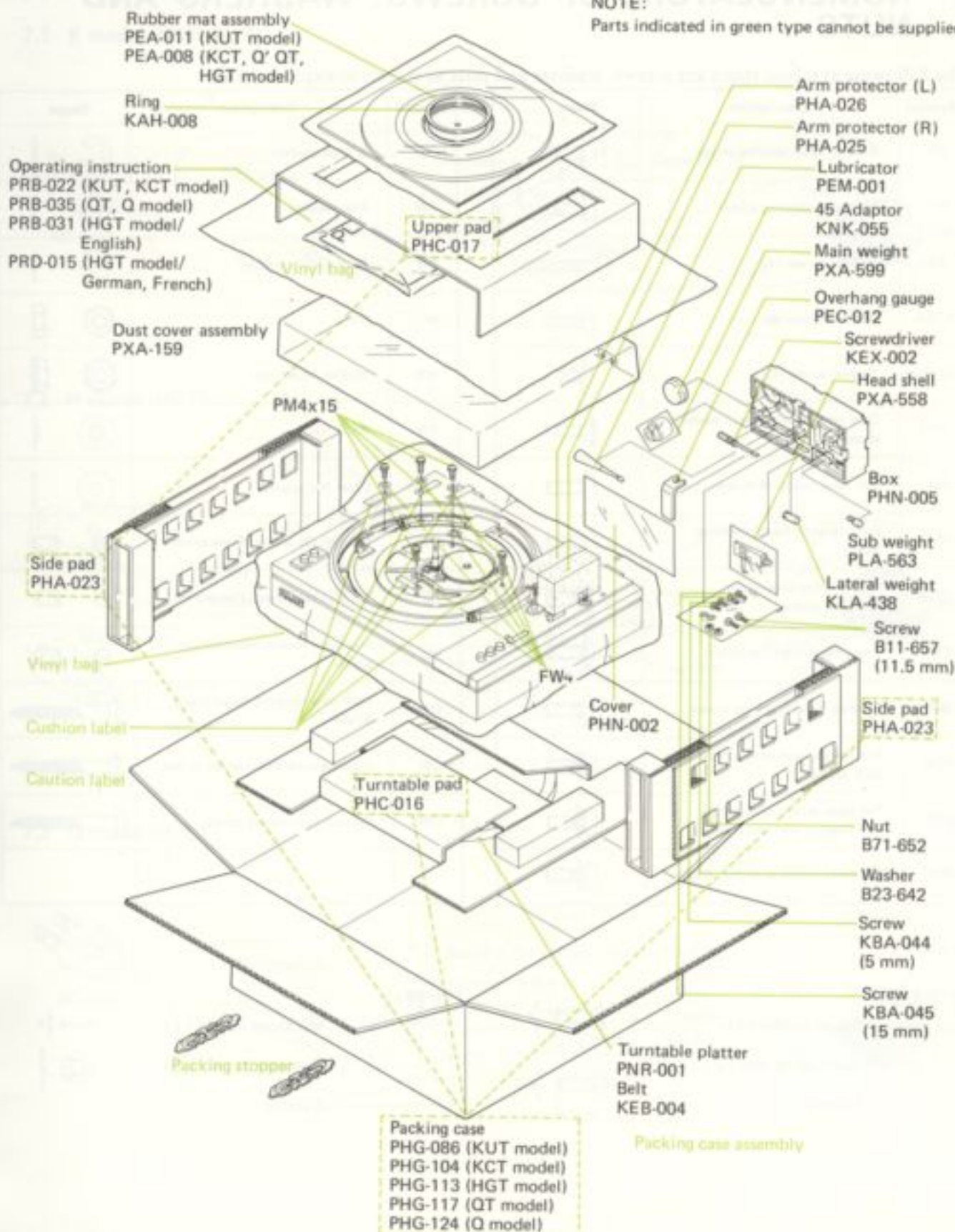





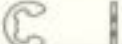

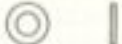











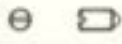

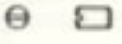
NOTE:

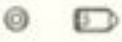
Parts indicated in green type cannot be supplied.

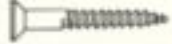

## 6. NOMENCLATURE OF SCREWS, WASHERS AND NUTS

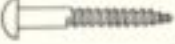
The following symbols stand for screws, washers and nuts as shown in exploded view.

Symbol	Description	Shape	Symbol	Description	Shape
RT	Brazier head tapping screw		EW	E type washer	
PT	Pan head tapping screw		FW	Flat washer	
PTT	Special screw (A)		SW	Spring lock washer	
PTBA	Special screw (B)		N	Nut	
POTBA	Special screw (C)		WN	Washer faced nut	
OCT	Oval countersunk head tapping screw		PN	Push nut	
PM	Pan head machine screw		FFW	Fiber flat washer	
CM	Countersunk head machine screw		SC	Slotted set screw (Cone point)	
OCM	Oval countersunk head machine screw		SF	Slotted set screw (Flat point)	
TM	Truss head machine screw		HS	Hexagon socket headless set screw	
BM	Binding head machine screw		OCW	Oval countersunk head wood screw	
PSA	Pan head screw with spring lock washer		CW	Countersunk head wood screw	
PSB	Pan head screw with spring lock washer and flat washer		RW	Round head wood screw	
PSF	Pan head screw with flat washer				

### EXAMPLE

PM · 3x8  
 length in mm ( $l$ )  
 diameter in mm ( $d$ )  
 Symbol



FW · 9φ x 1<sup>t</sup>  
 thickness in mm ( $t$ )  
 diameter in mm ( $d$ )  
 Symbol





## 7. WIRING

### 7.1 K model (KCT, KUT)

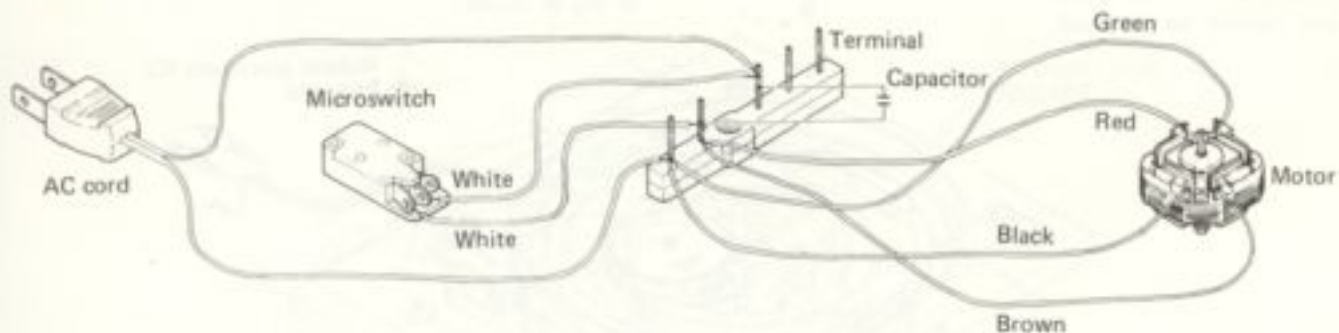

### 7.2 H model (HGT)

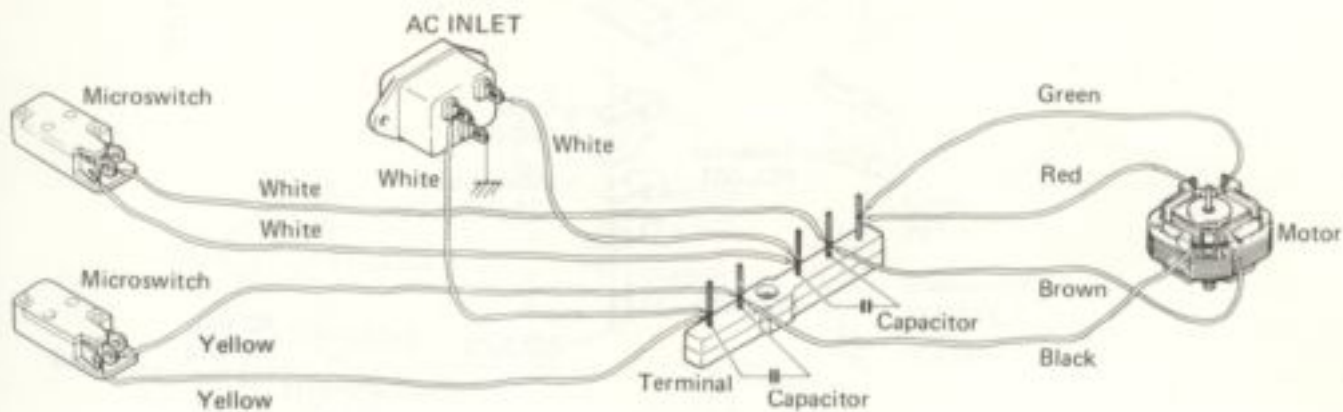

### 7.3 Q model (Q, QT)

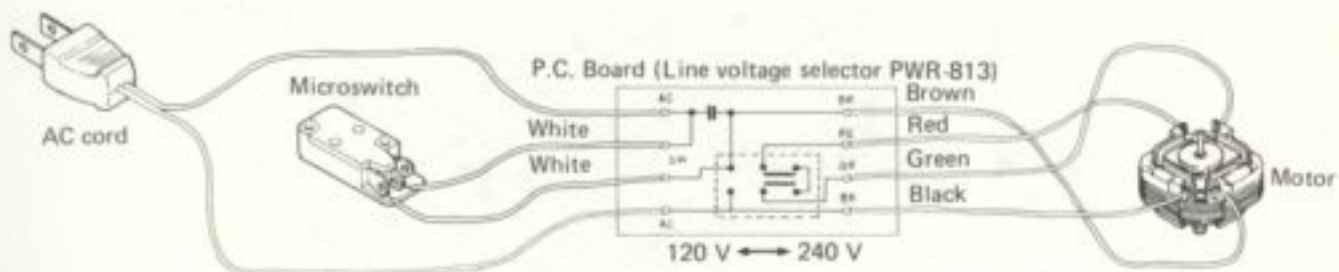

## 8. ADDITIONAL INFORMATION

### 8.1 HGT model

#### NOTE:

Parts indicated in green type cannot be supplied.

The parts indicated by designation and part numbers are newly-employed in the HGT, QT, Q model. The parts without description are the same as the parts in the K model.

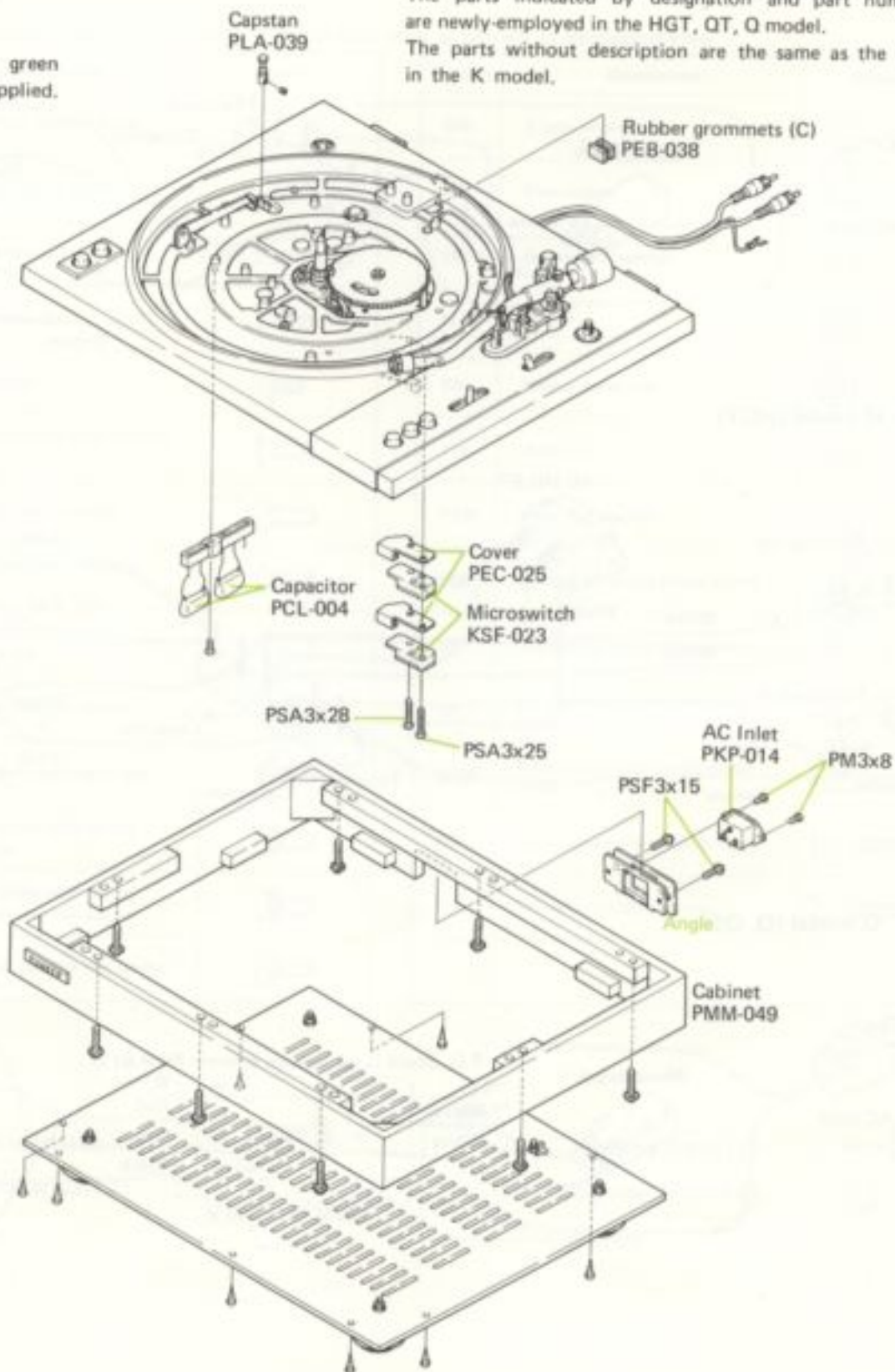

8.2 Q, QT model

NOTE:

Parts indicated in green type cannot be supplied.

Capstan  
 PLA-039 (50Hz)  
 PLA-040 (60Hz)  
 [A motor capstan for 50Hz (or 60Hz) is stored in the accessory box.]

AC power cord  
 PDG-004

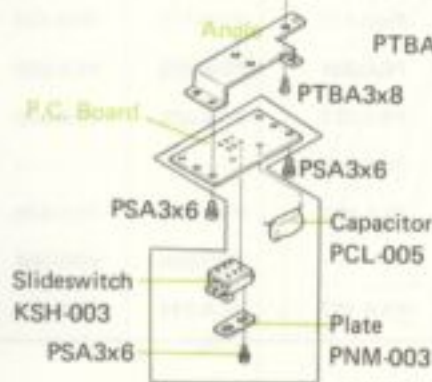
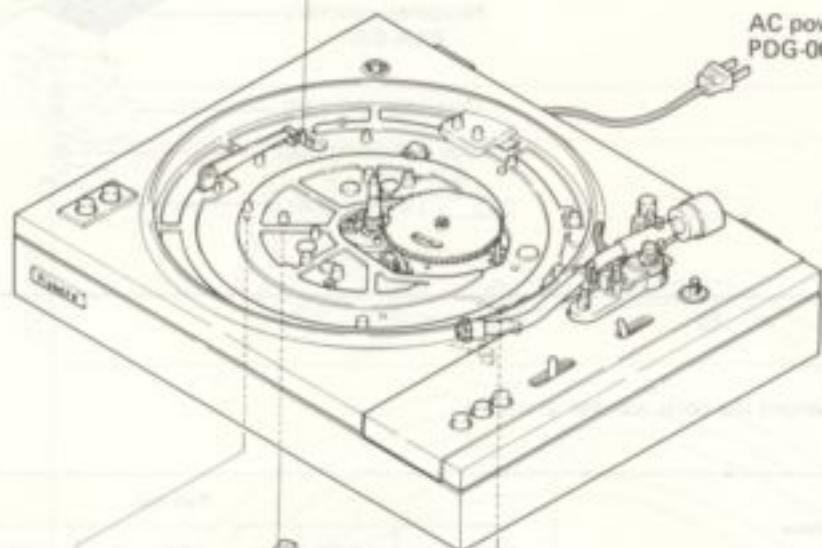

Line voltage selector assembly  
 PWR-813

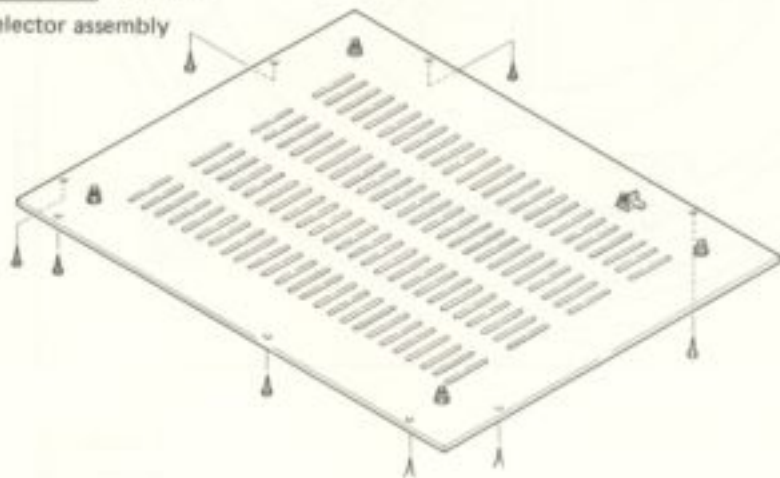

### 8.3 Q model

Since the phono cartridge PC-135 is equipped in the Q model, the cartridge mounting screws, nuts and washers are not provided in the accessory box.

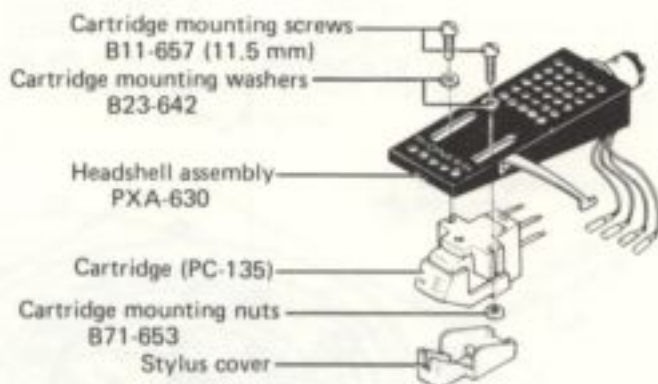

The following parts are changed the parts number as shown in the table.

Description	Part No.				
	KUT model	KCT model	HGT model	QT model	Q model
Packing case (on page 19)	PHG-086	PHG-104	PHG-113	PHG-117	PHG-124
Rubber mat assembly (on page 19)	PEA-011	PEA-008	PEA-008	PEA-008	PEA-008
Operating instructions (English) (on page 19)	PRB-022	PRB-022	PRB-031	PRB-035	PRB-035
Operating instructions (German/French) (on page 19)	.....	.....	PRD-015	.....	.....
Headshell assembly (on page 19)	PXA-558	PXA-558	PXA-630	PXA-630	PXA-630
AC power cord (on page 12,4-A block)	KDG-011	KDG-011	.....	PDG-004	PDG-004
Main plate assembly (on page 13, 2-B, C block)	PXA-219	PXA-220	PXA-187	PXA-214	PXA-214



## 9. SPECIFICATIONS (HGT model)

### Motor and Turntable

Motor .....	4-pole synchronous
Turntable drive .....	Belt-driven
Speed .....	Two speeds: 33-1/3rpm, 45rpm
Wow and flutter .....	0.07% (WRMS) or less
S/N .....	63dB (DIN B) or more (with Pioneer cartridge model PC-135)
Turntable platter .....	30cm diam. aluminum alloy
Moment of inertia .....	1.35kg-cm <sup>2</sup> (including rubber mat)

### Tonearm

Tonearm type .....	Static-balance, S-shaped, pipe arm
Effective arm length .....	221mm
Tracking error .....	+3° ~ -1°
Overhang .....	15.5mm
Usable cartridge weight .....	4g (min.) ~ 10g (max.) (For cartridge weighs over 8.5g, attach the sub weight)

### Sub Functions

- Fully automatic tonearm system
- Anti-skating force control device
- Plug-in type headshell
- Oil-damped arm elevator device
- Hinges (Free adjustable)
- Lateral balancer

### Miscellaneous

Power requirements .....	AC 220-240V, 50Hz
Power consumption .....	10W
Dimensions .....	440(W)x362(D)x159(H) mm 17-5/16(W)x14-1/4(D)x6-1/4(H) in.
Weight .....	7kg, 15 lb 6 oz

### Accessories

Headshell .....	1
Accessory oil .....	1
Overhang gauge .....	1
45rpm adaptor .....	1
Screwdriver .....	1
Sub weight .....	1
Cartridge mounting screws .....	6
Cartridge mounting nuts .....	2
Cartridge mounting washers .....	2
Operating instructions .....	1

For Use in United Kingdom only.

#### Please note:

Models employ 3-conductor mains leads. Please read the following instructions carefully before connecting.

**WARNING: THIS APPARATUS MUST BE EARTHED.**

**CAUTION 240V: MAINS SUPPLY VOLTAGE IS FACTORY ADJUSTED AT 240 VOLTS.**

### IMPORTANT

The wires in this mains lead are coloured in accordance with following code:

Green-and-yellow:	Earth
Blue:	Neutral
Brown:	Live

As the colours of the wires in the mains lead of this apparatus may not correspond with the coloured markings identifying the terminals in your plug proceed as follows.

The wire which is coloured green-and-yellow must be connected to the terminal in the plug which is marked by the letter E or by the safety earth symbol  $\perp$  or coloured green or green-and-yellow.

The wire which is coloured blue must be connected to the terminal which is marked with the letter N or coloured blue or black.

The wire which is coloured brown must be connected to the terminal which is marked with the letter L or coloured brown or red.

#### NOTE:

Specifications and design subject to possible modification without notice, due to improvements.

## 10. SPECIFICATIONS (QT, Q model)

### Motor and Turntable

Motor	4-pole synchronous
Turntable drive	Belt-driven
Speed	Two speeds: 33-1/3rpm, 45rpm
Wow and flutter	0.07% (WRMS) or less
S/N	63dB (DIN B) or more (with Pioneer cartridge model PC-135)
Turntable platter	30cm diam. aluminum alloy
Moment of inertia	135kg-cm <sup>2</sup> (including rubber mat)

### Tonearm

Tonearm type	Static-balance, S-shaped, pipe arm
Effective arm length	221mm
Tracking error	+3° ~ -1°
Overhang	15.5mm
Usable cartridge weight	4g (min.) ~ 10g (max.) (For cartridge weighs over 8.5g, attach the sub weight)

### Sub Functions

Fully automatic tonearm system
Anti-skating force control device
Plug-in type headshell
Oil-damped arm elevator device
Hinges (Free adjustable)
Lateral balancer

### Miscellaneous

Power requirements	AC 120V/240V switchable 50/60Hz
Power consumption	10W
Dimensions	440(W)x362(D)x159(H) mm 17-5/16(W)x14-1/4(D)x6-1/4(H) in.
Weight	7kg, 15 lb 6 oz

### Accessories

Headshell	1
Accessory oil	1
Overhang gauge	1
45rpm adaptor	1
Screwdriver	1
Sub weight	1
Motor puley	1
Cartridge mounting screws	6
Cartridge mounting nuts	2
Cartridge mounting washers	2
Operating instructions	1

(With phono cartridge model) screws, nuts and washers are not supplied.

## ABOUT FURNISHED CARTRIDGE

Type	Induced magnet type
Structure	The inside of the cartridge is shielded by Super permalloy; and the outside, injection-molded.
Frequency response	10 - 25,000Hz
Channel separation	More than 25dB at 1,000Hz
Output	3mV at 1,000Hz (50mm/s or 2in/s)
Channel balance	Within 1.5dB at 1,000Hz
Impedance	3.8kΩ at 1,000Hz
DC resistance	850Ω
Load resistance	50kΩ
Stylus	0.5 mil diamond (PN-135)
Dynamic compliance	10 x 10 <sup>-6</sup> cm/dyne
Tracking force requirement	1.5 - 2.3g (proper 2g)
Weight	5.4g
Overall dimensions	16(W)x17.9(H)x28.5(L)mm 5/8(W)x23/32(H)x1-1/8(L)in

*Life of stylus used in PC-135 is 800 to 1000 hours. If used for longer periods, record damage or noise can occur. Replace the stylus within this time or at first signs of wear.*



**NOTE:**  
Specifications and the design subject to possible modification without notice due to improvements.

## 11. OPERATING DESCRIPTION

Automatic operational functions of the PL-117D tonearm such as lead-in, lead-out and other functions are performed via a transfer from the center shaft gear A to gear B.

### TOP VIEW

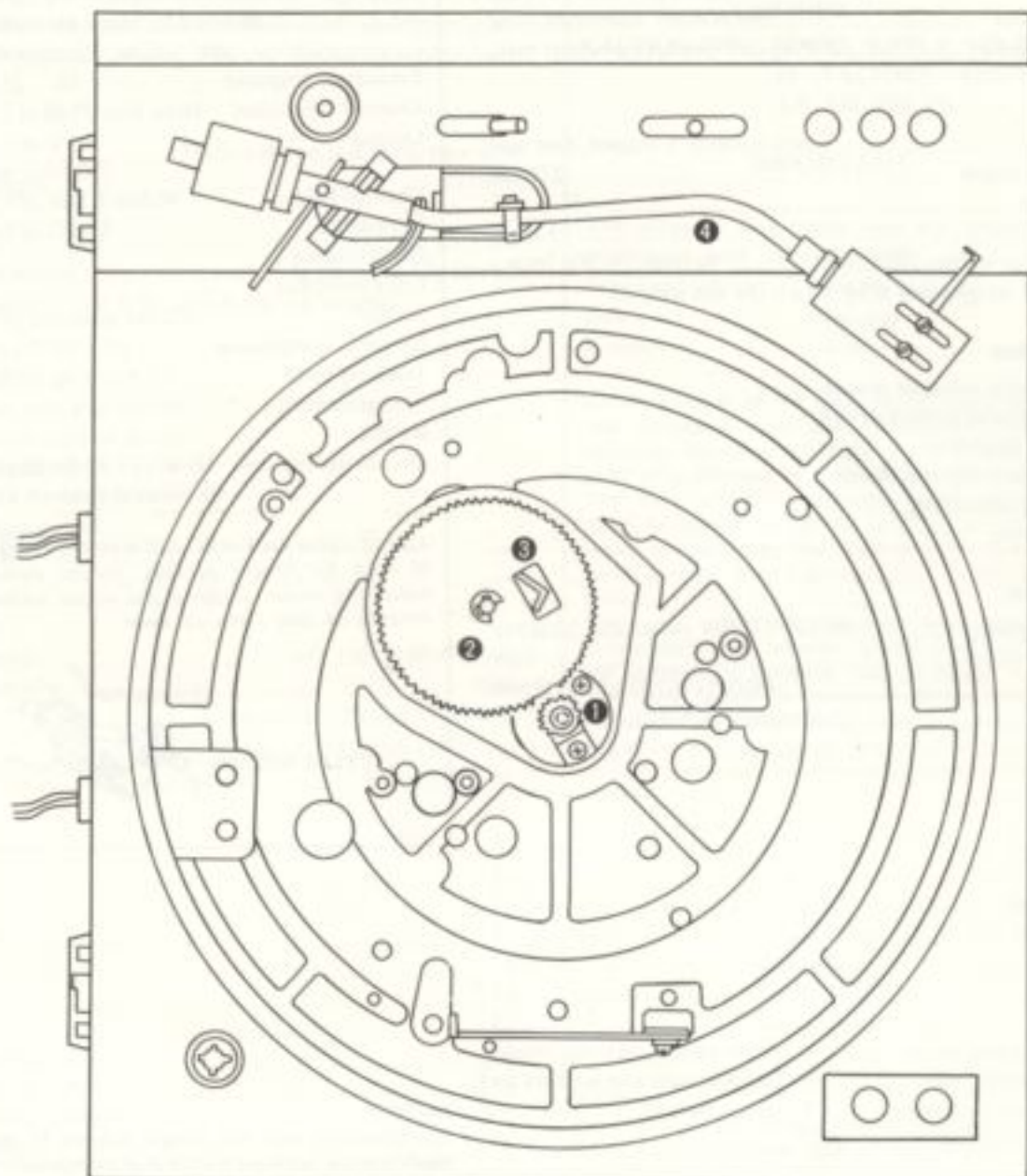

- ① ... Gear A
- ② ... Gear B
- ③ ... Arm B
- ④ ... Tonearm



BOTTOM VIEW

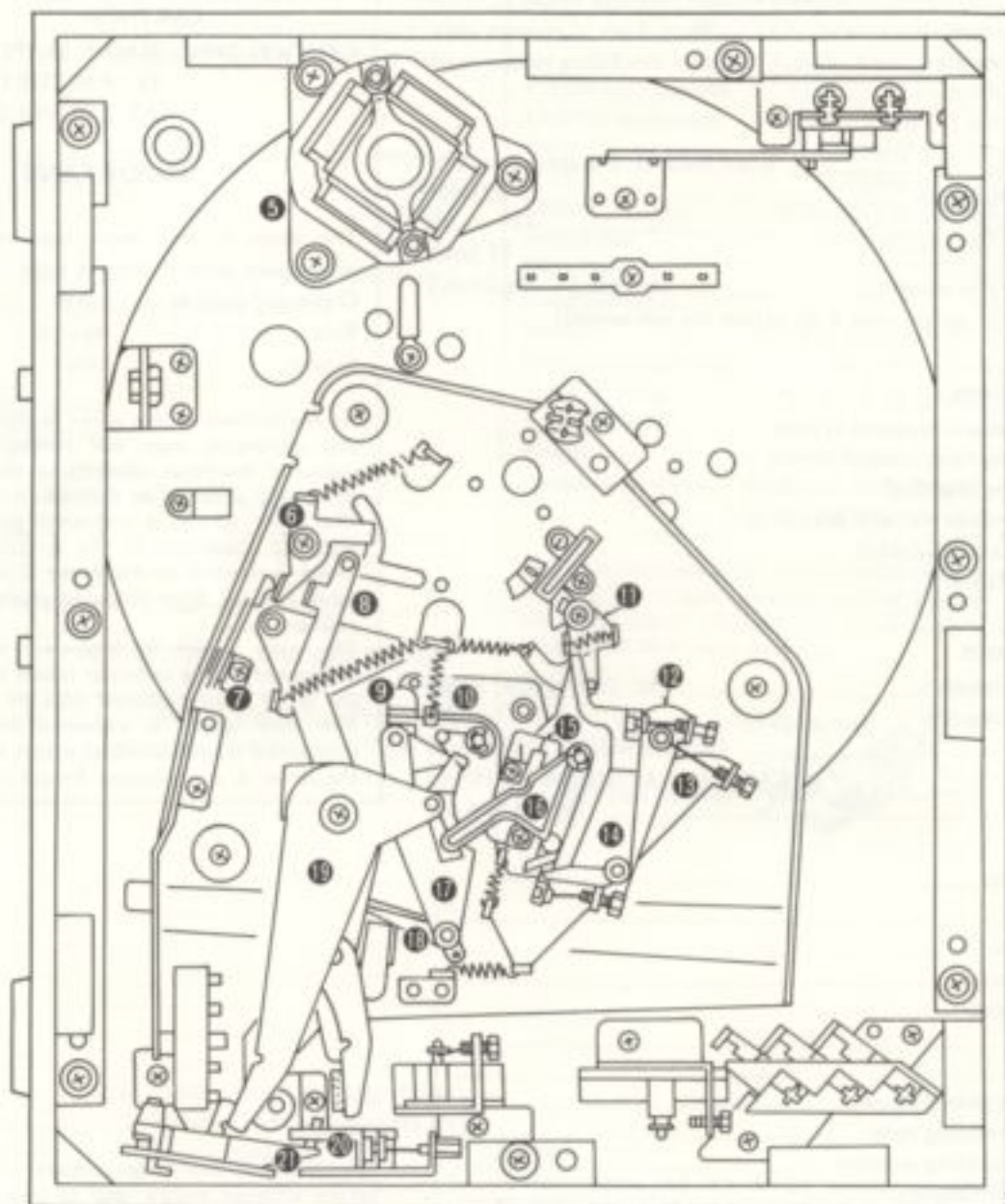

- |                     |               |                   |               |
|---------------------|---------------|-------------------|---------------|
| ⑤ ... Motor         | ⑩ ... Plate G | ⑭ ... Plate S     | ⑱ ... Plate E |
| ⑥ ... Plate H       | ⑪ ... Arm A   | ⑮ ... Microswitch | ⑲ ... Plate L |
| ⑦ ... Muting switch | ⑫ ... Plate F | ⑯ ... Plate J     | ⑳ ... Plate P |
| ⑧ ... Plate R       | ⑬ ... Plate G | ⑰ ... Plate K     | ㉑ ... Plate Q |
| ⑨ ... Plate M       |               |                   |               |



### 11.1 AUTOMATIC-OPERATION DETECTION

When in stop or play mode, counter-clockwise rotational force is applied to gear B by pawl A. However, gear B does not move since its stopper is restrained by mainframe plate A (Fig. 1).

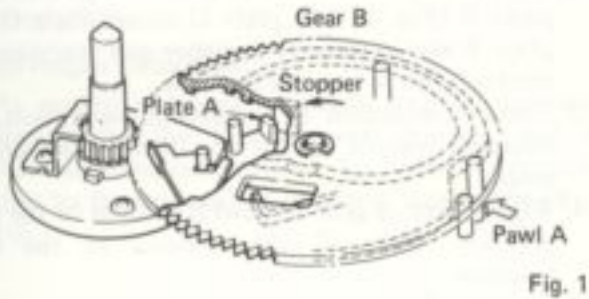

Fig. 1

Pressing the START or STOP button moves plate B and plate C above plate B presses against gear A (Fig. 2).

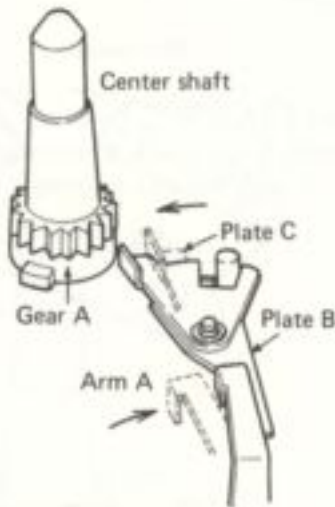

Fig. 2

Convex section of rotating gear A contacts plate C and plate A is then moved (Fig. 3).

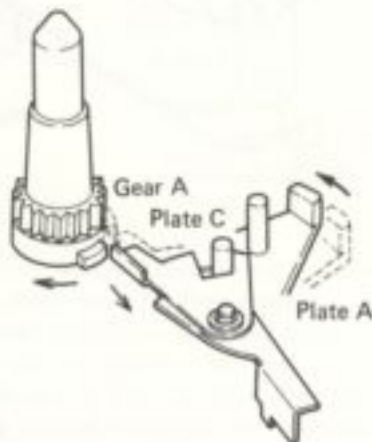

Fig. 3

When plate A moves, gear B stopper is released. Gear B turns counter-clockwise due to a force exerted by pawl A and engages gear A (Fig. 4).

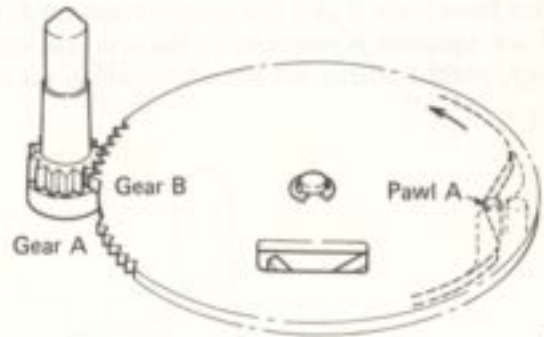

Fig. 4

Just prior to completion of gear B rotation, arm B returns plates A, B and C to their original positions (Fig. 5).

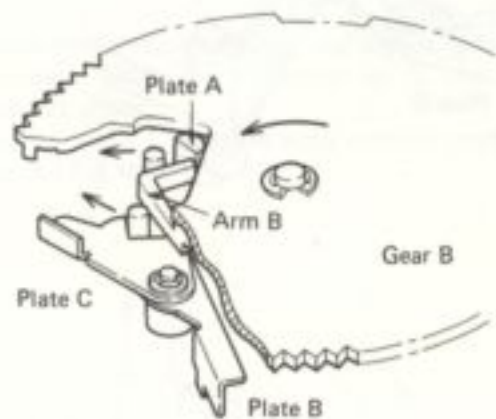

Fig. 5

Consequently, after a single rotation gear B stopper is again restrained by plate A. When the START button is pressed, the phono motor (PM) immediately starts and the platter rotates.

## 11.2 MICROSWITCH ON-OFF

### Manual Operation (Figs. 6 & 7)

1. Plate D is directly coupled to the tonearm shaft and moves when the tonearm is removed manually from the arm rest.
2. This frees plate E and the microswitch turns ON.
3. If the tonearm is returned to the arm rest during play, plate D turns off the microswitch via plate E.

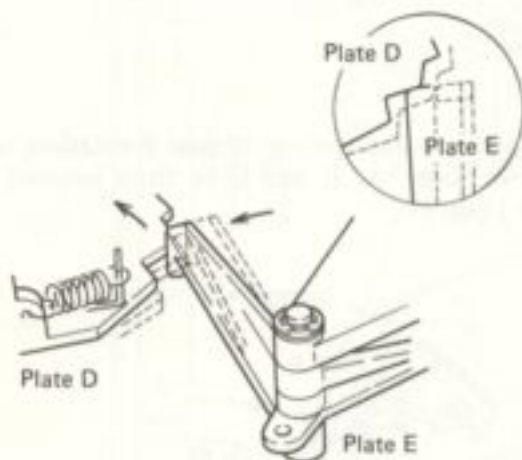

Fig. 6

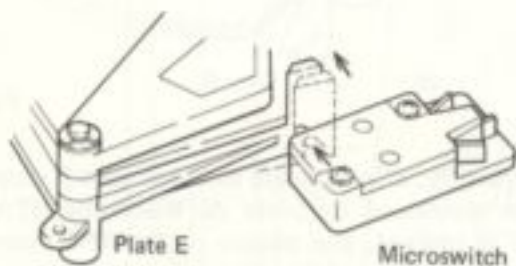

Fig. 7

### Automatic Operation:

1. Pressing the START button moves plate F via wire A and the microswitch turns ON (Fig. 8).
2. The motor rotates and as gear B begins to turn, pawl B (Fig. 9) and plate G move. Plate G and plate F above it move together and maintain the microswitch in the ON position.
3. Upon completion of automatic operation, the tonearm returns to the arm rest before gear B stops.
4. With 1 turn of gear B, pawl B returns to the start position. Plate G also returns to the start position.
5. As plate F returns to the start position together with plate G, the microswitch is turned OFF by plate E.

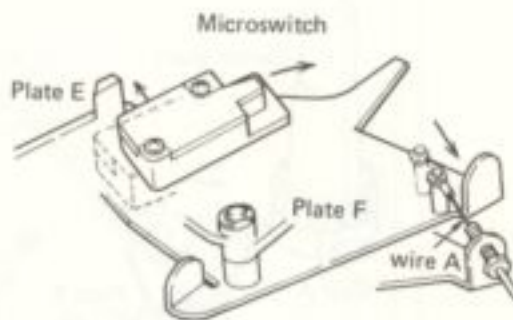

Fig. 8

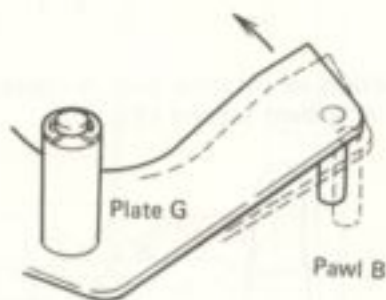

Fig. 9

### 11.3 AUTO-CUT AND AUTO-RETURN DETECTION

The tonearm is automatically returned to the arm rest at the completion of record play. Also, if the STOP button is pressed while a record is being played, the tonearm automatically returns and playing ceases.

#### Auto-return Detection:

1. As record playback proceeds and the tonearm approaches the inner record grooves, rod A (directly coupled to plate D) moves in proportion to the amount of tonearm movement (Fig. 10).



Fig. 10

2. Rod A pushes plate B and plate C above plate B moves in the direction toward gear A (Fig. 11).

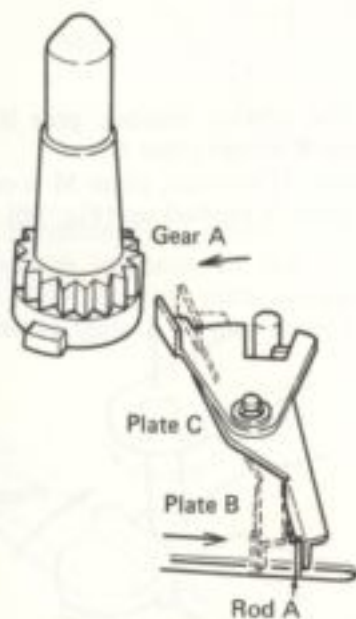

Fig. 11

3. As the stylus moves 1mm toward the center of the record with each platter rotation, the end of plate C moves approximately 0.12mm.
4. The raised convex portion of gear A possesses a taper, as shown in Fig. 12. While stylus is within 1.5mm per platter rotation, this tapered portion pushed back on plate C (Fig. 13).

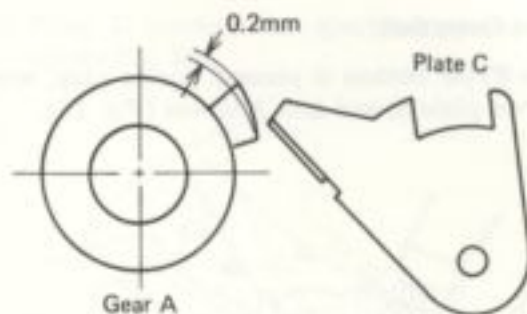

Fig. 12

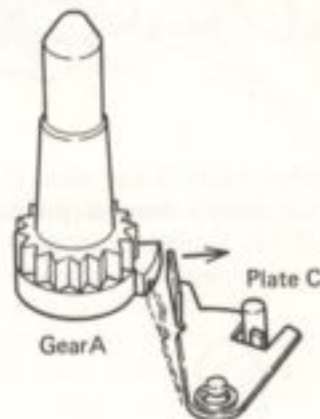

Fig. 13

5. Upon completion of play, the stylus movement becomes 3mm per rotation as it enters the lead-out grooves.
6. End of plate C engages with convex portion of gear A (Fig. 14).

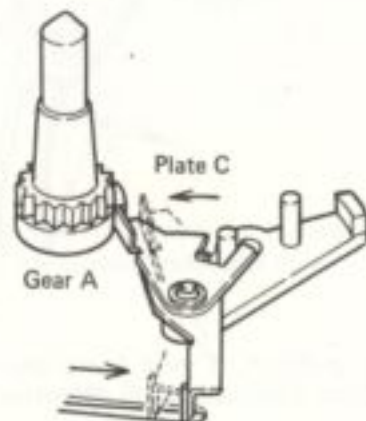

Fig. 14

7. As plate C is moved by gear A, plate A moves and gear B stopper is released and gears A and B engage\*.
- \* See Section 11.1 Auto-Operation Detection.



### Auto-cut Detection:

1. If the STOP button is pressed during play, wire B moves plate S, and arm A moves (Fig. 15).

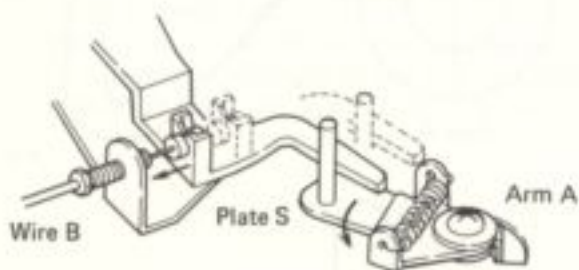

Fig. 15

2. Arm A pushes plate B and plate C above plate B contacts the raised convex portion of gear A (Fig. 16).

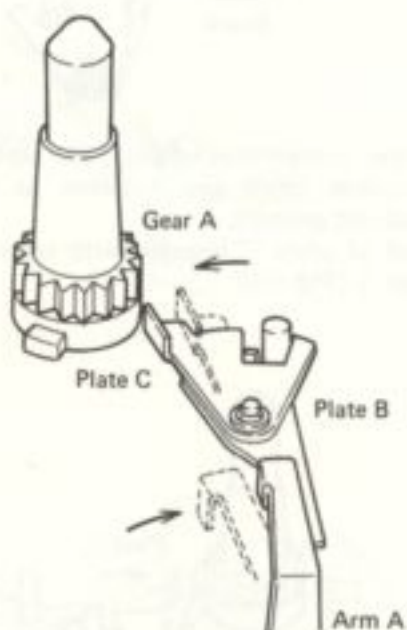

Fig. 16

3. Convex portion of gear A engages with plate C to perform auto operation detection.

### 11.4 TONEARM OPERATION

#### Auto Lead-in:

1. Plate F moves when the START button is pressed. The microswitch turns ON and platter rotates.
2. Since plate J above plate F also moves, plate K is pulled disengaging the pin on plate L (Fig. 17).

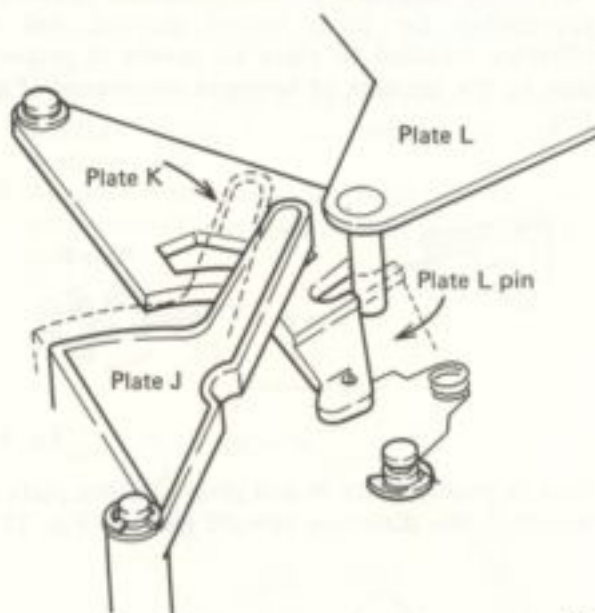

Fig. 17

3. When the platter rotates, gear B also rotates and pawl B moves plate G.
4. With plate G motion, plate M is contacted and pin of plate N pushed up (Fig. 18).

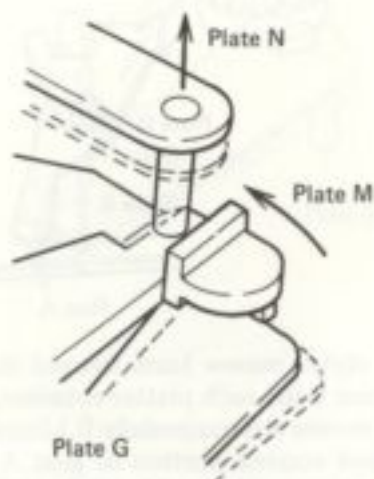

Fig. 18

5. Plate N sets the tonearm elevation UP.

6. While gear B makes a  $\frac{1}{2}$  turn, gear B groove moves pawl C of plate R toward pin shaped section of plate D (Fig. 19).

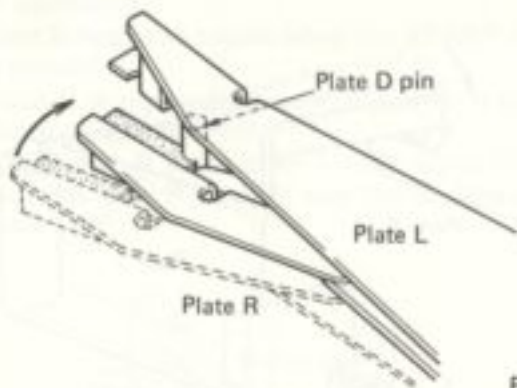

Fig. 19

7. The pin section is gripped by plates R and L (Fig. 20).

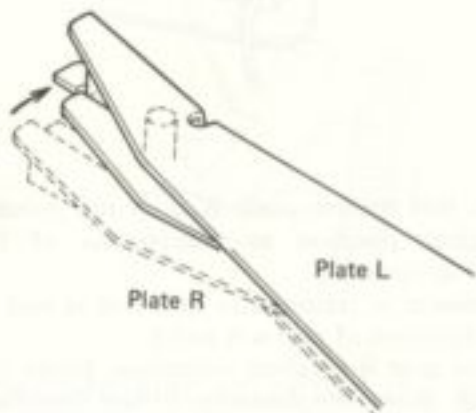

Fig. 20

8. Since gear B continues to rotate, plate S moves in the direction opposite to that of Step 6. Movement of the friction plate between plates R and L causes plate L to also move (Fig. 21).

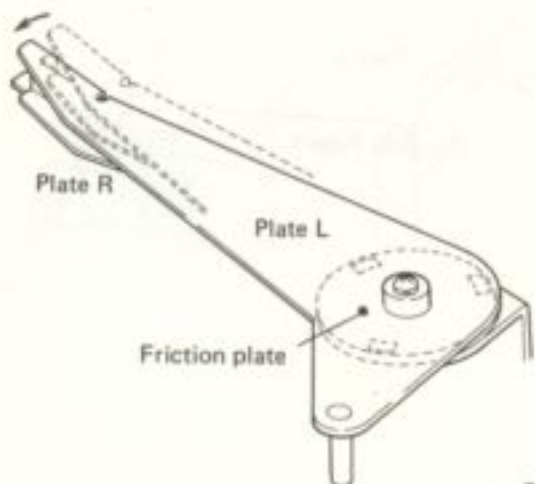

Fig. 21

9. Plate L reaches the specified position, then stops (Fig. 22).

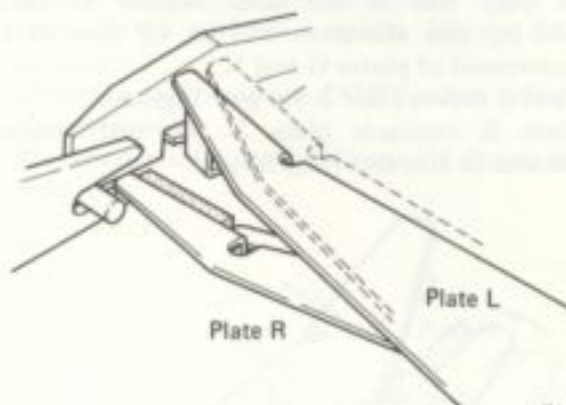

Fig. 22

10. When gear B turns once, plates G and N return to their original positions. At this point, the tonearm elevation is lowered and the stylus descend onto the record.

11. When plate G returns to its original position, plate J (at plate F above plate G) returns plate K to its original position (Fig. 23).

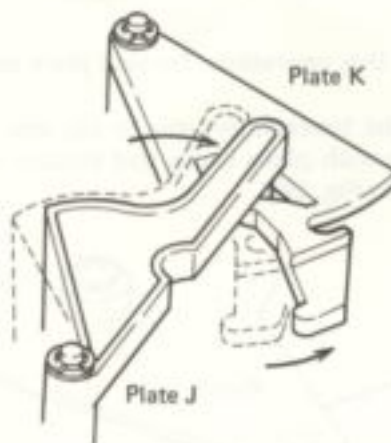

Fig. 23

12. Although plate K tends to return, since arm lead-in is completed restrains plate K (Fig. 24).

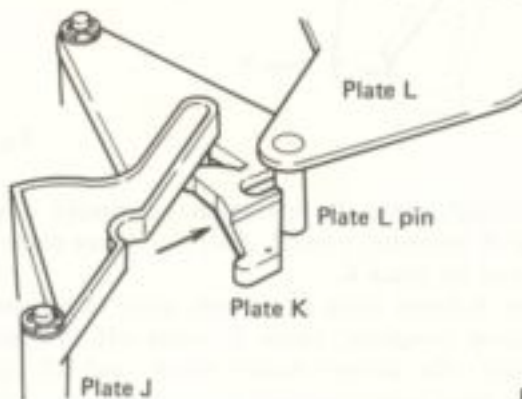

Fig. 24

### Lead-out:

1. Gear B begins to rotate when plate C detects end of play and in the same manner as during lead-in, arm elevation will be UP due to the movement of plates G and N.
2. Pawl C moves plate R via gear B groove.
3. Plate R contacts plate D pin and tonearm returns to arm rest (Fig. 25).

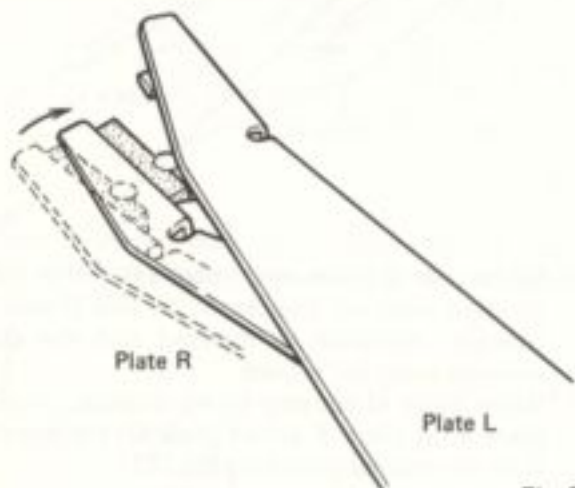

Fig. 25

### Auto-repeat Detection:

1. When REPEAT button is pressed, plate J position is shifted by wire C (Fig. 27).

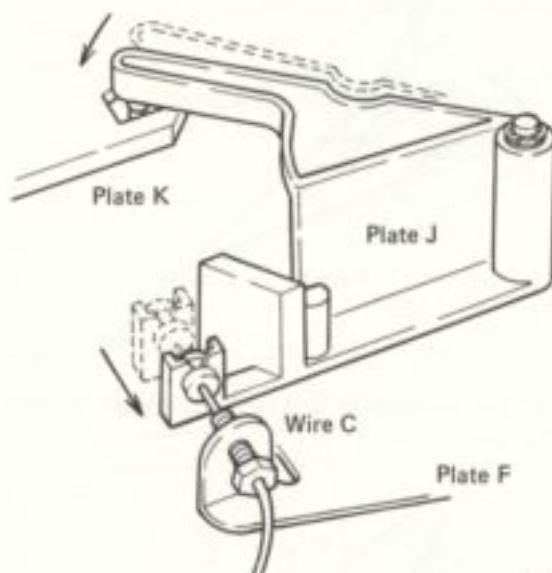

Fig. 27

4. During this operation, friction plate moves plate L.
5. When the tonearm returns to the arm rest, plate K locks with plate L pin and returns to original position (Fig. 26).

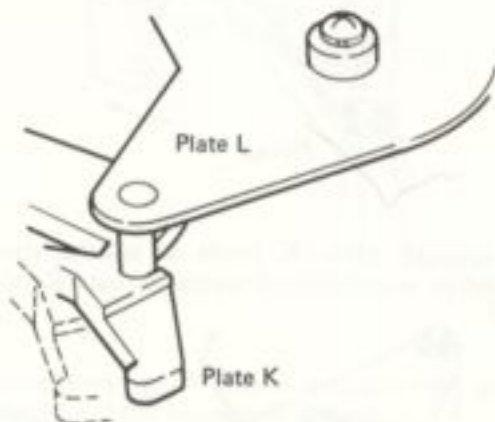

Fig. 26

2. For this reason, plate K does not return to its original position at completion of tonearm lead-in operation.
  3. Tonearm is returned to arm rest at end of play by function of plates R and L.
  4. Since gear B rotation continues, plates R and L again move the tonearm to the specified position.
  5. By pressing the STOP button, plate S motion can release the repeat mode (Fig. 28).
- \* Repeat mode is not obtained when plate K locks plate L pin.

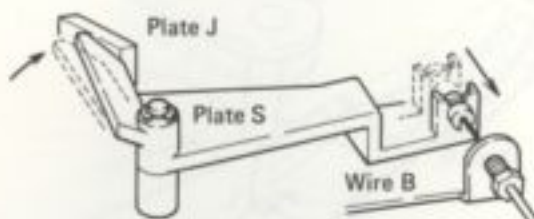

Fig. 28

6. Although plate R operation continues due to gear B rotation, plate L does not move since it is locked by plate K.
7. Gear B turns once and when plate G returns to original position, plate E turns off the micro-switch, the phono motor stops, and all operations have been completed.



**11.5 MUTING SWITCH ON-OFF (Fig. 29)**

This switch shorts the output signal from the cartridge and functions to cut noise during mechanism operation.

1. Gear B begins to rotate when the START button is pressed.
2. Plate H is released by stopper on gear B and sets the muting switch ON.
3. When gear B stops after 1 turn, plate H again contacts gear B stopper and the muting switch turns OFF.

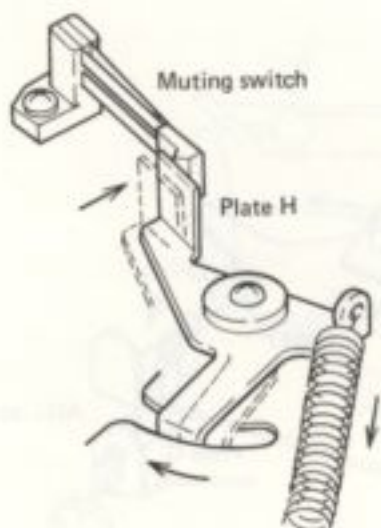

Fig. 29

**11.6 RECORD SIZE SELECTOR (Fig. 30)**

1. When the SIZE lever is moved, wire D moves plate P and plate Q position changes.
2. This changes plate L stop position and the tonearm will be brought to the 17, 25, or 30 cm record position.

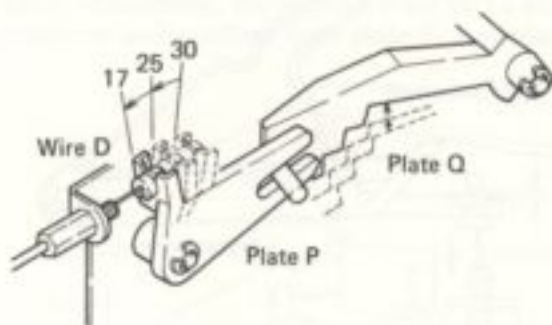

Fig. 30

**11.7 ARM ELEVATION (Fig. 31)**

1. When the ARM ELEVATION lever is moved, wire E moves plate M then plate N pin move vertically to perform tonearm UP and DOWN operation.
2. Elevation mechanism is DOWN when using stop or play modes.
3. Elevation mechanism is always UP during gear B rotation.

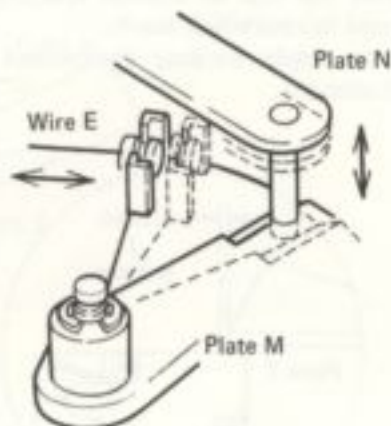

Fig. 31

## 12. ADJUSTMENTS

Adjustments are performed in the mode sequence start-repeat-stop.

### 12.1 START ADJUSTMENTS (Fig. 32)

1. Observe that gear B, plates G and F etc., are completely in stop mode.
2. Press START button (set to depressed position).
3. As shown in Fig. 32, turn the adjusting screw and adjust for 0.2 to 0.3mm spacing between plate E and microswitch knob.
4. Be sure to apply locking compound to screw after adjustment.

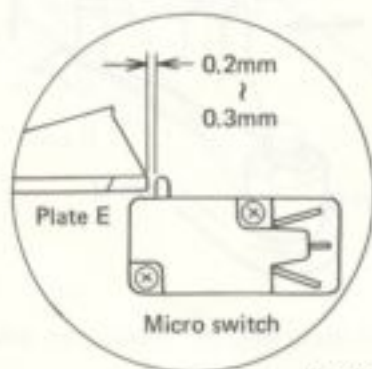

Fig. 32-a

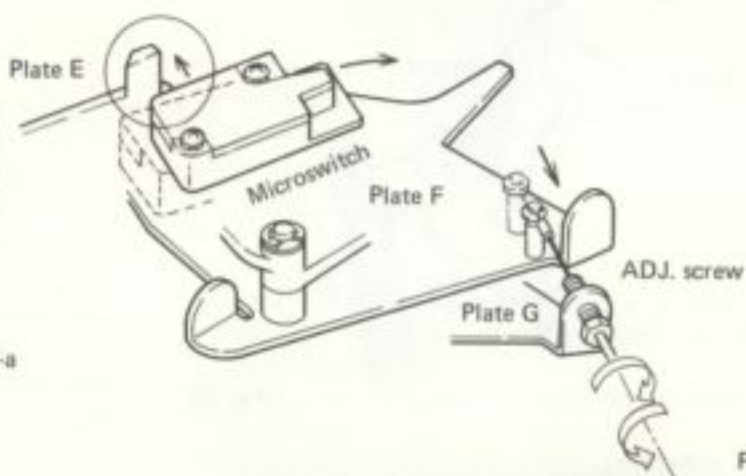

Fig. 32-b

### 12.2 REPEAT ADJUSTMENT (Fig. 33)

1. Plate J position is shifted when the REPEAT button is pressed.
2. A steel ball provides click-stop for plate J in the normal and repeat positions.
3. Adjust screw so that click-stop is correctly performed.
4. Be sure to apply locking compound to screw after adjustment.

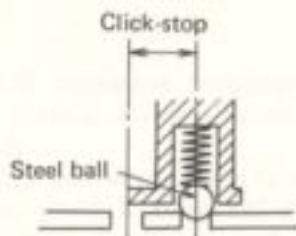

Fig. 33-a

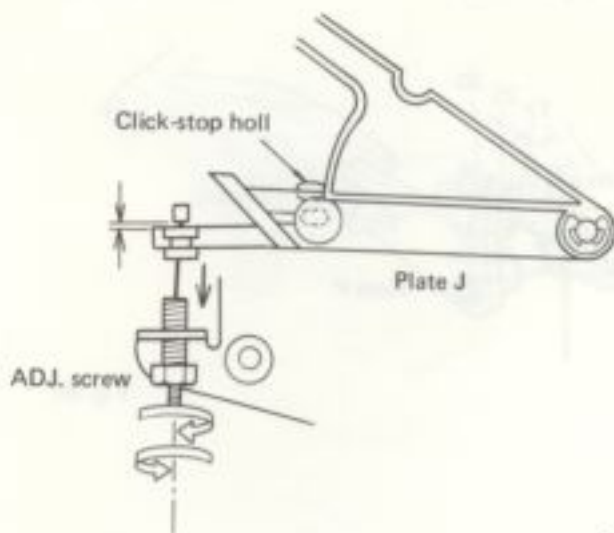

Fig. 33-b

### 12.3 STOP ADJUSTMENT (Fig. 34)

1. Wire moves plate S when STOP button is pressed.
2. Adjust screw so that point A in Fig. 34 is 0.5 to 1.0mm when plate S moves.
3. Confirm that when the STOP button is released, plates S and F do not shift at point B in Fig. 35.

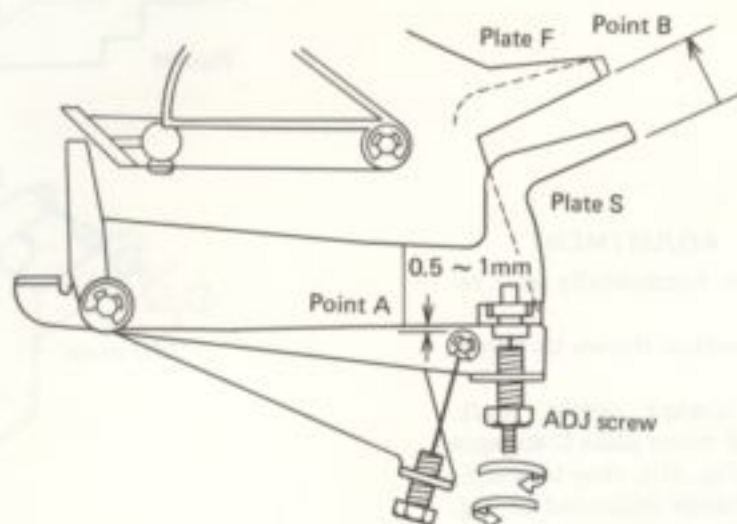

Fig. 34

### 12.4 SS OPERATING SECTION ADJUSTMENT

1. Set SIZE lever to 25.
2. Press START button. Tonearm auto lead-in will function.
3. Stop when plate L contacts plate Q.
4. So that the position indicated in Fig. 35 becomes 2 mm, turn adjusting screw.
5. After adjustment, move SIZE lever to 17 and 30 positions and confirm that plate L is contacted.

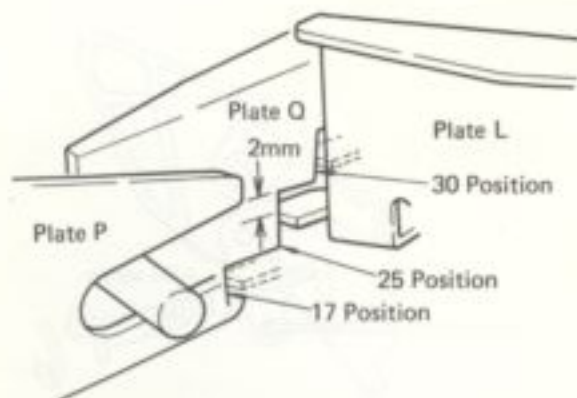

Fig. 35

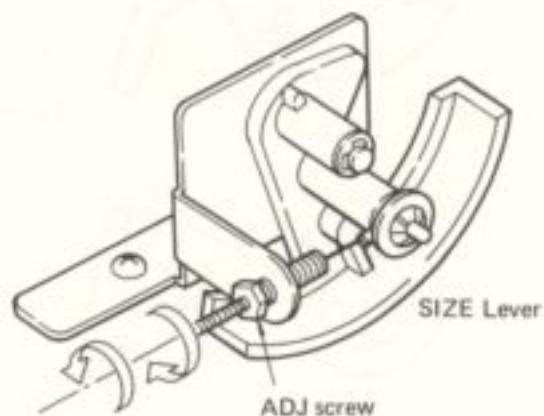

Fig. 36



## 12.5 EV OPERATING SECTION ADJUSTMENT

1. ARM ELEVATION lever moves plate M via wire E to raise and lower plate N.
2. When arm elevation is UP, so that spacing between plate M and pin of plate N shown in Fig. 37 becomes 0.3 mm, adjust screw shown in Fig. 38.
3. After adjustment, confirm that pin of plate N rides smoothly up and down on slanted section of plate M.

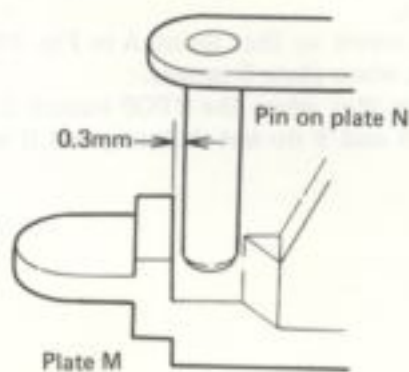

Fig. 37

## 12.6 RETURN POSITION ADJUSTMENT

1. Remove cabinet, place set horizontally and remove gear B.
2. Move plate A fully in direction shown by arrow in Fig. 39.
3. Move tonearm gently toward center shaft.
4. Rod A presses plate B and when plate C engages raised portion of gear A (Fig. 40), stop tonearm.
5. At this time, so that distance indicated in Fig. 41 becomes  $62 \pm \frac{1}{2}$  mm, adjust screw shown in Fig. 42.

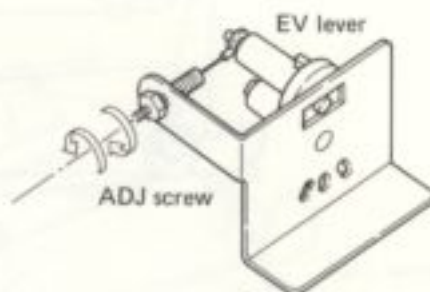

Fig. 38

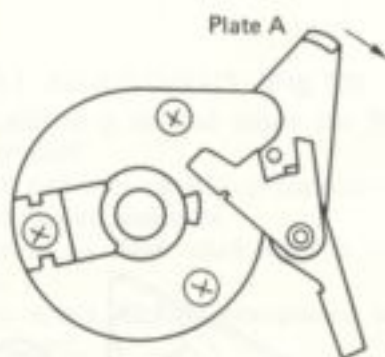

Fig. 39

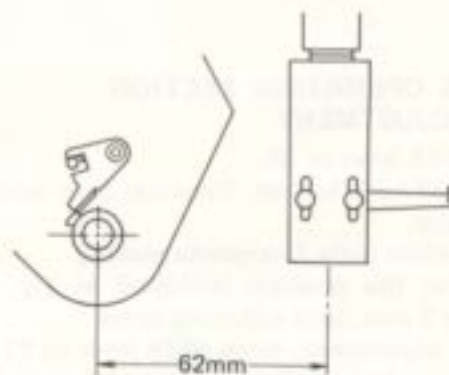

Fig. 41

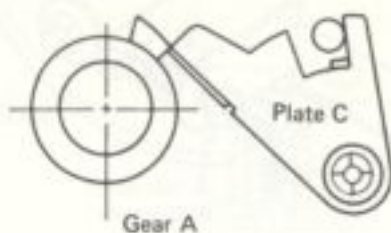

Fig. 40

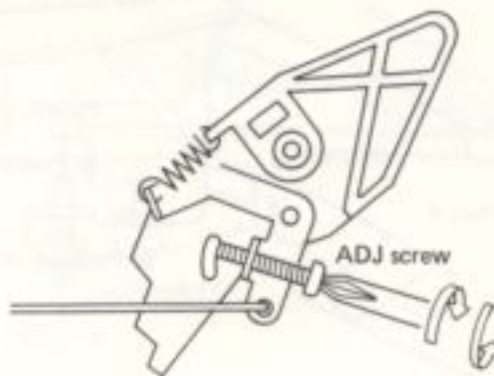

Fig. 42

**PIONEER ELECTRONIC CORPORATION**

4-1, Meguro 1-Chome, Meguro-ku, Tokyo 153, Japan

**U.S. PIONEER ELECTRONICS CORPORATION**

75 Oxford Drive, Moonachie, New Jersey 07074, U.S.A.

**PIONEER ELECTRONIC (EUROPE) N.V.**

Luithagen-Haven 9, 2030 Antwerp, Belgium

**PIONEER ELECTRONICS AUSTRALIA PTY. LTD.**

179-184 Boundary Road, Breezide, Victoria 3185, Australia

© MAY 1976

Printed in Japan